



INSTALLATION, OPERATION AND SERVICE MANUAL



Single Pantograph Scissors Subterranean Parking Lift

by

Autoquip

P.O. Box 1058 • 1058 West Industrial Avenue • Guthrie, OK 73044-1058 • 888-811-9876
405-282-5200 • FAX: 405-282-3302 • www.autoquip.com

830VLS

Version 1.0
June 2009

© 2009 AUTOQUIP CORPORATION

This manual and the information herein is the sole property of Autoquip Corp. and shall not be reproduced without written consent by Autoquip

TABLE OF CONTENTS

Introduction	4
Responsibility of Owners/Users	5
Pre-Installation Site Visit	6
Safety Signal Words	7
Safety Practices	8
Safety Features	13
Label Identification	16
Specifications	20
Lift Blocking Instructions	21
Installation Instructions	24
Operating Instructions	38
Routine Maintenance	40
General Maintenance	42
Replacement Parts List	50
Troubleshooting Analysis	53
Glossary of Terms	57

IMPORTANT

Please read and understand this manual prior to installation or operation of this unit. Failure to do so could lead to property damage and/or serious personal injury. If any questions arise, call a local representative or *Autoquip Corporation* at 1-888-811-9876 or 405-282-5200.

PLANNED MAINTENANCE PROGRAM

A local *Autoquip* representative provides a Planned Maintenance Program (PMP) for this equipment using factory-trained personnel. Call a local representative or *Autoquip Corporation* at 1-888-811-9876 or 405-282-5200 for more information.

INTRODUCTION

Autoquip Corporation has manufactured this product to move vehicles between floors or levels safely and efficiently. It has been built to provide many years of dependable service. Proper installation of this equipment is vital to both the efficiency of the unit and the ultimate satisfaction of the end user. **It is vital for the installers to read and understand this manual!** These instructions have been prepared and organized to assist the installers and it is important for these individuals to carefully follow the steps in the order they are presented!

Situations may arise which are not covered in these installation instructions. If you have questions, please call *Autoquip* Customer Service at (405) 282-5200 or 1-888-811-9876.

NOTE: Unless otherwise stated, mechanical installation does not include unloading, permits, seismic calculations, or extensive acceptance testing. The requirements of each contract should be carefully reviewed for possible conflicts of interpretation.

UPON DELIVERY OF THE EQUIPMENT

Upon receipt of the shipment, check for exposed damage or shortages and make note of it on the trucking company Bill of Lading or the Shipping Papers. Reports of concealed damage to items contained in crates must be reported within 48 hours. DO NOT destroy the crating while opening it to inspect the contents. If damage is suspected or found, report it directly to the carrier. DO NOT contact *Autoquip Corporation*!! All shipments are FOB from the *Autoquip* plant. **Any claims for damage must be filed with the carrier. Any parts shipped from *Autoquip* that are intended to replace damaged or lost items will be invoiced to the ordering party.**

Assuming no damage has occurred to the crate, check the components against the packing list. This will provide assurance that every item shipped has been received. Everything needed for the installation should be available. If not, report any shortages to *Autoquip Corporation* within 10 days. (*Autoquip* is not responsible for parts lost, stolen or damaged during transportation, storage, installation, or during any other circumstances or conditions that may be beyond corporate control.)

RESPONSIBILITY OF OWNERS/USERS

DEFLECTION

It is the responsibility of the user/purchaser to advise the manufacturer where deflection may be critical to the application.

INSPECTION & MAINTENANCE

The lift shall be inspected & maintained in proper working order in accordance with Autoquip's operating/maintenance (O&M) manual and safe operating practices.

REMOVAL FROM SERVICE

Any lift not in safe operating condition such as, but not limited to, excessive leakage, missing rollers, pins, or fasteners, any bent or cracked structural members, cut or frayed electric, hydraulic, or pneumatic lines, damaged or malfunctioning controls or safety devices, etc. shall be removed from service until it is repaired to the original manufacturer's standards.

REPAIRS

All repairs shall be made by qualified personnel in conformance with Autoquip's instructions.

OPERATORS

Only trained personnel and authorized personnel shall be permitted to operate the lift.

BEFORE OPERATION

Before using the lift, the operator shall have:

- Read and/or have explained, and understood, the manufacturer's operating instructions and safety rules.
- Inspect the lift for proper operation and condition. Any suspect item shall be carefully examined and a determination made by a qualified person as to whether it constitutes a hazard. All items not in conformance with Autoquip's specification shall be corrected before further use of the lift.

DURING OPERATION

The lift shall only be used in accordance with Autoquip's O&M manual.

- Do not overload the lift.
- Ensure that all safety devices are operational and in place.

MODIFICATIONS OR ALTERATIONS

Modifications or alterations to industrial lifting equipment shall be made only with written permission of Autoquip. Autoquip does not foresee and does not anticipate unauthorized modifications, and these changes or alterations are grounds for voiding all warranties.

PRE-INSTALLATION SITE VISIT

SITE CONDITIONS

Whenever possible, make a pre-installation visit or call someone at the site. Installers must be familiar with everything relative to proper installation of this equipment. Some concerns are listed below, though listing every affecting contingency is impossible. It is the installer's responsibility to check the site for problems and work out solutions with the appropriate people. Some of the areas of concern are:

1. Is the site accessible to large delivery & cartage vehicles?
2. Can the lift components get through the existing doorways & floor openings?
3. How will the unit be raised, set into position, and accessed?
4. Can a chain fall be hooked to an available overhead support?
5. Is there a forklift or other cartage equipment available?
6. Look for problem areas such as bracing and overhead interference with ceilings, joists, pipes, etc..

It is always best to be prepared, so do as much pre-planning as possible before the installation procedure actually begins. Learn about the site, the equipment, and the installation process.

SAFETY SIGNAL WORDS

SAFETY ALERTS (Required Reading!)

The following SAFETY ALERTS are intended to create awareness of owners, operators, and maintenance personnel of the potential safety hazards and the steps that must be taken to avoid accidents. These same alerts are inserted throughout this manual to identify specific hazards that may endanger uninformed personnel. Identification of every conceivable hazardous situation is impossible. Therefore, all personnel have the responsibility to diligently exercise safe practices whenever exposed to this equipment.



DANGER!

Identifies a hazardous situation which, if not avoided, will result in death or severe personal injury.



WARNING!

Identifies a hazardous situation which, if not avoided, could result in death or serious personal injury.



CAUTION!

Identifies a hazardous situation which, if not avoided, may result in minor or moderate personal injury.

NOTICE

Identifies a potentially hazardous situation which, if not avoided, may result in property or equipment damage.

SAFETY PRACTICES



DANGER!

High voltage! May cause personal injury or death. Repairs should only be performed by a qualified service/control technician!!



DANGER!

Never go under a lift platform! To avoid personal injury or death, always be sure the load has been removed from the platform and that it has been blocked from underneath! See “Blocking Instructions” section.



DANGER!

Qualified personnel only! Only qualified service personnel should perform procedures labeled as “dangerous”!



DANGER!

Be sure of equipment stability! To avoid personal injury or death, check for stability. If the unit seems unstable, do not operate! Contact *Autoquip* immediately!



DANGER!

Turn off power during inspection & maintenance! To avoid personal injury or death, be sure the power is off and is locked per OSHA Lock-out, Tag-out procedures!

SAFETY PRACTICES



DANGER!

Practice field safety procedures! To avoid personal injury or death, utilize all applicable precautions for steel erection and equipment assembly in addition to OSHA regulations for lock-out, tag-out, etc.!



DANGER!

Secure platform and cylinders! Do not remove or disconnect the power unit unless the platform and cylinders have been secured and all hydraulic pressure has been relieved. See “Blocking Instructions” section.



WARNING!

No riders! The PhantomPark Lift is provided for the sole purpose of transporting vehicles between floor elevations. At no time should it be used to transport personnel!!



WARNING!

Never run the unit with the gates or doors open! Do not operate unit with doors open or with the interlocks or other safety devices and sensors “defeated” (bypassed)! Serious injury or death could result.



WARNING!

Velocity fuse lock-up requires factory help! Contact your local PhantomPark Lift representative or call Autoquip Service Department if hydraulic velocity fuses should lock up!

SAFETY PRACTICES



WARNING!

Secure unit before making static inspections! Make sure the platform is fully lowered and the power is turned off (disconnected at the safety disconnect switch) before performing static inspections. Place signs at all gates, doors, controls, etc. indicating the system is temporarily out of service for routine maintenance per OSHA requirements for Lock-Out, Tag-Out.



WARNING!

Never operate unit when parts are defective! Do not operate this equipment when damaged, substandard or defective parts are in use! Contact an Autoquip Service Representative to rectify all such situations.



WARNING!

Use high pressure hydraulic components only! Never use fittings or hoses that are not properly rated for 3,000 psi service.



WARNING!

Use approved or prescribed procedures only! If any procedure prescribed in this manual cannot be followed or adhered to for any reason, IMMEDIATELY cease what is being done and contact an Autoquip Service Representative for assistance. Autoquip can not foresee the possible misuses of this equipment caused as a result of not following prescribed installation, operation, and maintenance procedures.



WARNING!

The velocity fuse (VF) must be properly installed! The VF is attached directly to the port of the cylinder. If the VF is installed improperly, it will not lock up in the event of a catastrophic hydraulic line break!

SAFETY PRACTICES



WARNING!

Authorized personnel only in the lift area! A minimum 36” clear distance is recommended for authorized personnel whenever raising or lowering vehicle.



WARNING!

Familiarize yourself with operators manual before operating this lift.



WARNING!

Operator only in the lift area during operation.



WARNING!

Never exceed rated capacity of lift.



WARNING!

If any component of this lift is believed to be defective – do not operate lift.



WARNING!

Always ensure maintenance devices are engaged before any attempt is made to work on or beneath lift.

SAFETY PRACTICES



WARNING!

Failure to follow these instructions can result in severe personal injury or death.



CAUTION!

Lift to be used by trained operator only!

CAUTION!

Use appropriate fluids! Do not use automatic transmission fluid (ATF), hydraulic jack oil, hydraulic fluids, or brake fluids in the power unit or hosing system. Use 5W30 motor oil or other approved fluids only.

CAUTION!

Keep power unit filled! Do not run the hydraulic power unit dry. Damage to the pump and motor may result.

CAUTION!

Do not operate motor at relief pressure! The motor should not be operated for more than a few seconds when the unit is operating at relief pressure. Longer running times could result in damage to the pump.

CAUTION!

Avoid air in the system! The presence of air in the system can lead to a lock-up of the velocity fuses. (Air reacts like a spring when it is compressed.)

SAFETY FEATURES

There are several primary active safety features and devices to help protect personnel, property, and the equipment.

HYDRAULIC VELOCITY FUSES

Each hydraulic cylinder has a hydraulic velocity fuse (HVF) installed in the cylinder port. These HVFs are installed in the down circuit with a predetermined maximum hydraulic oil flow volume/velocity as the oil returns to the reservoir. They do not affect incoming oil. Should a catastrophic rupture or breach occur in the hydraulic system and oil flows through the breach that exceeds the HVF rating, the HVF will trigger and lock up. This lock up will occur with one to two inches of downward movement of the platform carriage.

NOTE: Air in the system will also cause a lock up. Air acts like a spring when compressed. To remove air from the system, see “Air Bleeding Procedures” in the General Maintenance section.

NOTE: Small fitting leaks will trigger the HVFs. In an air-free system, the breach must be large enough to cause an uncontrolled or destructive lowering speed. Should a triggering and lock up occur, it can only be released by applying upward hydraulic flow in a functional system.

SAFETY RELEASE BYPASS VALVE (SRBV)

The SRBV is a part of the hydraulic system. Should the system pressure exceed the predetermined pressure setting, the SRBV will bypass the pump output back to the oil reservoir. The SRBV is factory set to the proper pressure, which will prevent damage to the mechanical, hydraulic, and electrical systems due to overloading, obstruction, or other circumstances.

MOTOR STARTER OVERLOADS (MSO)

These are current sensing devices that are located in the three legs of the electric motor primary power circuit (208,230, or 460 volt). They protect the motor from excessive current draw if it becomes overloaded, experiences low line voltage, or has a short circuit. Should any leg sense an over-current situation the element will heat up and trip the heat sensitive device housed in the motor starter coil circuit. Power is removed to the coil and the three line power contacts are opened in the motor primary power circuit. This will stop the motor from rotating until the overloads are reset and/or the fault is cleared which caused the trip condition.

NOTE: The MSO will only affect the “UP” circuit. The platform carriage can be lowered if the MSO trips.

SAFETY FEATURES

CONTROL TRANSFORMER SECONDARY FUSE

This fuse is attached to the electrical control transformer and protects the 24 volt control circuit from damage should a fault occur which would result in excessive electric current flow. Should the fuse activate (blow) it will prevent the operation in either direction and the interlock circuit will not operate. These fuses are located in the control enclosure.



DANGER!

High voltage! May cause personal injury or death. Repairs should only be performed by a qualified electrician or service technician and OSHA requirements for Lock-Out, Tag-Out must be followed!!

SAFETY INTERLOCKS/LATCHES-GATES OR DOORS **(where applicable)**

These are electro/mechanical devices that prevent operation of the Lift when the gates or doors are left open on any level. They also prevent the gates or doors from being opened at any level unless the platform carriage is in the home (stored) position.



WARNING!

Never run the unit with the gates or doors open! Do not operate unit with doors open or with the interlocks “defeated” (bypassed)!

BEVELED TOE GUARDS (BTG)

Fixed mechanical toe guards are welded around the perimeter of both decks at an inward slant of approximately 30 degrees from vertical to protect toes during operation as the canopy deck descends past the edge of the garage floor into home position.

KEY LOCK-OUT STATION

Separate electrical device which requires a key to turn the control system “On”. This station is shipped loose and is wired in the circuit between the control panel and the operator pushbutton station to prevent unauthorized operation of the lift.

E-STOP STATION **(optional)**

Emergency Stop “panic” button which, when pushed, removes electrical power from the control circuit and immediately stops lift movement. E-Stop stations can be located at upper or lower level locations, and must be manually reset to continue operation.

SAFETY FEATURES

KEY PAD STATION

(optional)

A key pad security station can be purchased in lieu of a keyed security station to turn the control system “On”. This station is shipped loose and is wired in the circuit between the control panel and the operator pushbutton station to prevent unauthorized operation of the lift.

ADJUSTABLE WHEEL STOPS

(optional)

These mechanical devices can be adjusted to help ensure that a vehicle being parked on the lower deck for storage is located completely within the perimeter of the deck so as to prevent damage to the vehicle or the lift as the vehicle is lowered from the upper level to the lower level.

ULTRASONIC VEHICLE POSITION INDICATOR

(optional)

This simple, electronic device mounts to a wall in front of the lift and can be adjusted to ensure that a vehicle being parked on the lower deck for storage is located completely within the perimeter of the deck so as to prevent damage to the vehicle or the lift as the vehicle is lowered from the upper level to the lower level.

VEHICLE-PRESENT SENSORS

(optional)

These photo-eye sensors look across the upper deck of the lift when it is in the home or fully lowered position to “see” whether a vehicle is present on the deck or not. If a vehicle is sensed, the photo-eye switch opens a contact in the control circuit and operator will not be able to activate the “UP” button to raise the deck .

PLATFORM MOVEMENT ALARM

(optional)

An audible and/or visual signaling device which will activate any time the “UP” or “DOWN” pushbutton is pressed to notify anyone in the area that the lift is being operated.

PHOTO EYE INTERFERENCE DETECTION

(optional)

These photo-eye sensors look across an edge of the lift to detect any type of potential interference from items that would get close enough to break the photo eye beam. If broken, the photo-eye switch opens a contact in the control circuit and operator will not be able to operate the lift.

HYDRAULIC LOCKING PINS

(when ordered – typically for lifts without canopies)

Automatic locking pins are mounted in the lift carriage to maintain the elevation of the lift when in the raised position to and to keep it level with the surrounding floor during edge loading of the lift, and/or to counter any drift due to gradual hydraulic pressure loss.

LABEL IDENTIFICATION

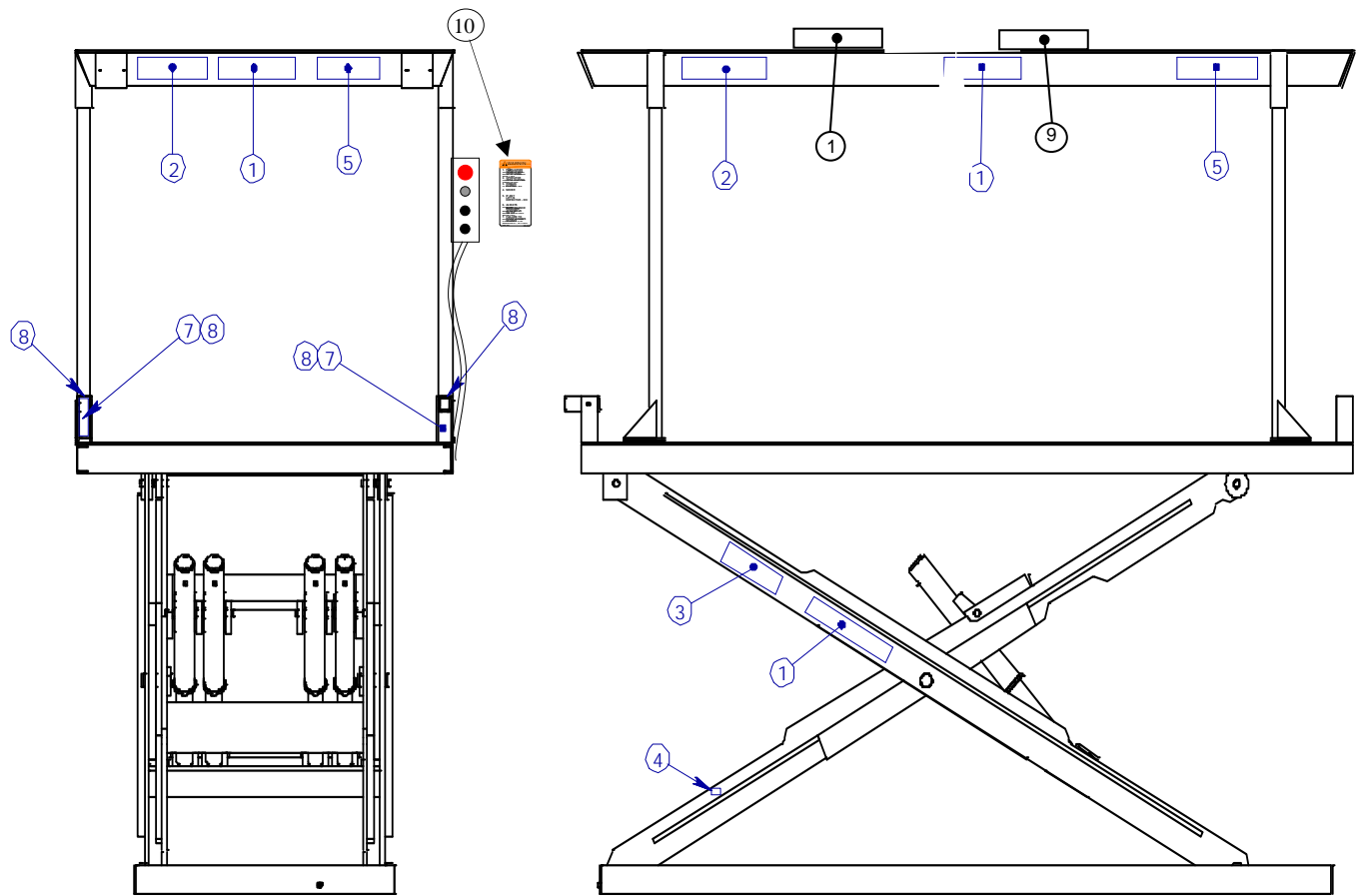

Figure 1 Label Placement

Subterranean Scissors Lift			
Item No.	Qty	Description	Part No.
1	5	Caution! Familiarize Yourself With Operators Manual	36401487
2	4	Danger – Do Not Put Hands or Feet . . .	36430050
3	2	<i>Autoquip</i> Serial Number Nameplate	36401511
4	2	UP – STOP Valve Warning	36401610
5	4	Capacity	36401594
7	4	Maintenance Device	36400257
8	8	WARNING! Do Not Tamper	36405695
9	2	<i>Autoquip</i> logo	36403225
10	2	Operator Warning placard (shipped loose)	36403993

LABEL IDENTIFICATION

Note: Labels shown here are not actual size.



Figure 2 Label 36401487



Figure 3 Label 36430050



Figure 4 Label 36401511

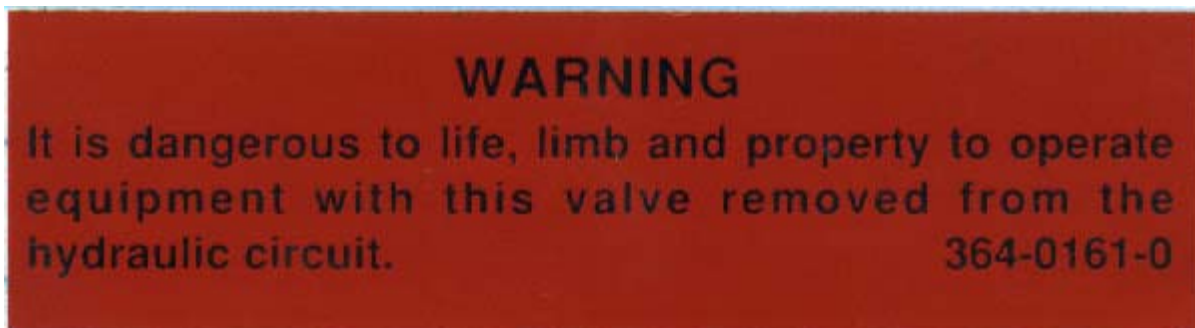

Figure 5 Label 36401610

LABEL IDENTIFICATION



Figure 6 Label 36401594



Figure 8 Label 36400257



Figure 9 label 36405695

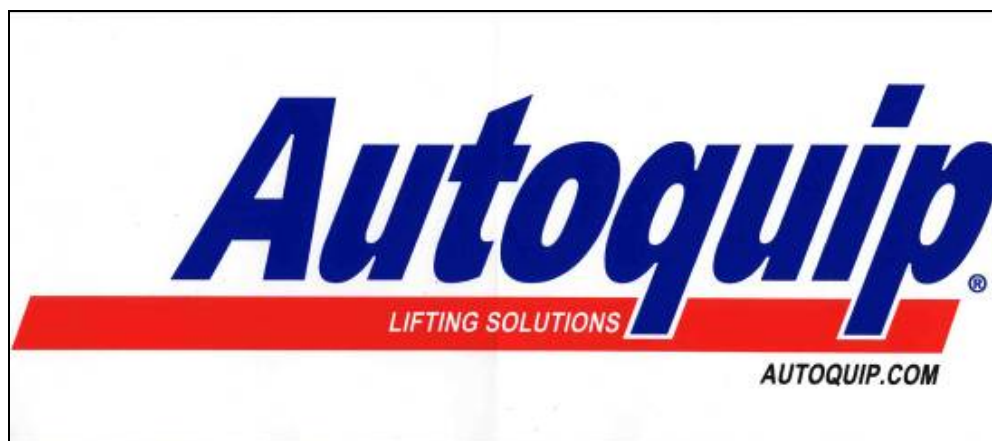
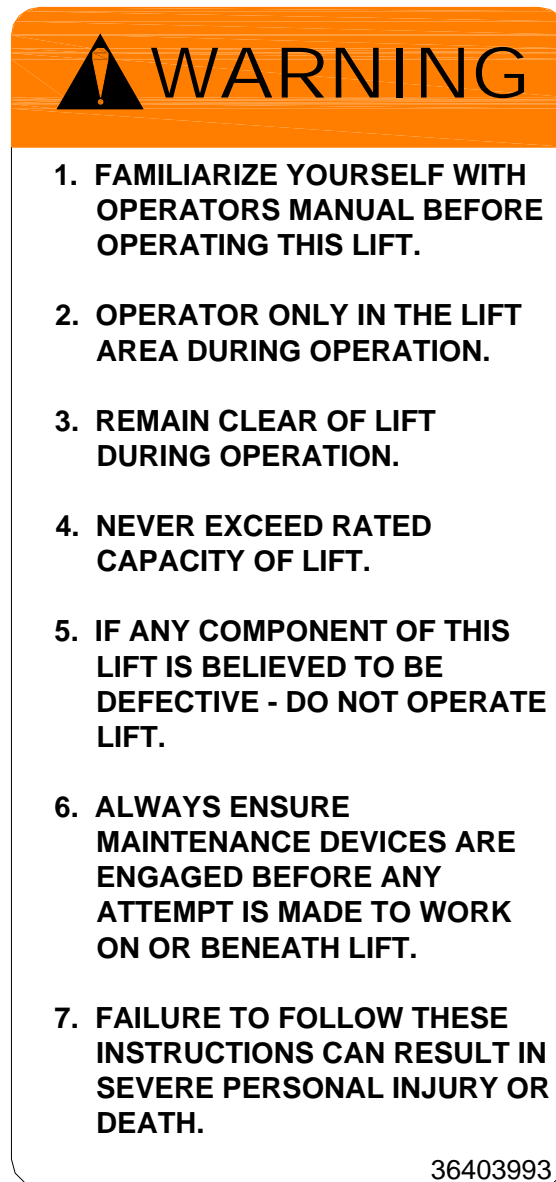

Figure 10 Label 36403225

LABEL IDENTIFICATION



Field-locate & apply this decal adjacent to the lift at each level, ideally in the vicinity of the operator pushbutton station.

Figure 11 Label 36403993

SPECIFICATIONS

Model Number	Lift Capacity (lbs)	Lift Travel (in)	Axle Load Capacity (lbs)	Platform and Canopy Size (in)	Base Frame Size (in)	Max Lowered Height (in)	HP 230V 1ph	Up Speed (sec)	Down Speed (sec)
96VLS70	7,000	96	4,000	108 X 216	72 X 186	20	5	107	54
108VLS70	7,000	108	4,000	108 X 216	72 X 186	20	5	120	60
120VLS70	7,000	120	4,000	108 X 216	72 X 186	20	5	134	67
132VLS70	7,000	132	4,000	108 X 216	72 X 208	27	5	325	163
144VLS70	7,000	144	4,000	108 X 224	72 X 216	29	5	326	163
156VLS70	7,000	156	4,000	108 X 246	72 X 238	29	5	435	220
168VLS70	7,000	168	4,000	108 X 216	72 X 156	34	5	340	170
180VLS70	7,000	180	4,000	108 X 216	72 X 156	34	5	360	180
192VLS70	7,000	192	4,000	108 X 216	72 X 156	34	5	195	153

LOAD CAPACITY

The load capacity rating is stamped on a metal plate attached to one side of the lift. This figure is a net capacity rating for a lift furnished with the standard platform. The relief valve of the pumping unit has been set to raise the weight, plus a small amount for overload. **Lifts should not be overloaded beyond the established capacity as damage and/or personal injury may result.**

APPROVED LOADING & UNLOADING

The stabilization provided is based on the application and assumes that the lift is loaded in the raised position over the clevis (hinged) end of the platform. **Lifts should not be loaded or loaded in any way other than the intended load pattern approved and provided by Autoquip as damage and/or personal injury may result.**

PUMP PRESSURE

This lift incorporates a positive displacement pump machined to a high degree of accuracy and specially adapted to requirements of higher-pressure ranges over that of a standard pump. Therefore, standard factory models of the same manufacture cannot replace it.

The pump can operate efficiently at intermittent pressures up to 3200 PSI and continuous duty to 2500 PSI. The safety relief valve in the pump assembly is factory-set to stay within the parameters of the pump and lift requirements.

LIFT BLOCKING INSTRUCTIONS



WARNING !

Only trained and qualified personnel should perform inspection or maintenance and service procedures.



DANGER !

Failure to properly adhere to lift blocking procedures is to risk the sudden and uncontrolled descent of the lift during maintenance or inspection. A falling lift can cause severe injury or death.

This procedure describes the only factory-approved method of working under a lift table. Follow these instructions ANY time you plan to reach or work beneath the lift – no matter how momentary that might be.

If the factory-provided maintenance device is damaged or missing, stop immediately and consult the factory for assistance. The manufacturer is not liable for your failure to use the approved maintenance devices and procedures that have been provided.

1. All load must be removed from the lift prior to engaging the maintenance device. These devices are designed to support an unloaded lift only. Failure to remove the load from the lift prior to blocking could allow the lift to fall unexpectedly, resulting in permanent damage to or failure of the maintenance device and/or lift table.
2. Lower the empty deck until the four (4) maintenance locks make contact with the surrounding floor. (See **Figure 12**)
3. As an added level of protection when using the locking devices at floor level, it is recommended that a secondary stop be placed underneath the lower deck such as four (4) 4" x 4" treated wood posts that have been cut to the appropriate length.

LIFT BLOCKING INSTRUCTIONS



DANGER !

If for any reason you are unable to lower the lift completely onto the maintenance device(s), stop immediately and consult the factory. Failure to properly use the factory approved maintenance device(s) could result in severe injury or death.

4. Once the maintenance device(s) are properly engaged, continue to press the down button or switch for an additional 5-10 seconds to relieve all hydraulic/pneumatic pressure in the system.



DANGER !

Failure to relieve lift table system pressure could result in the sudden and unexpected release of pressure during maintenance and/or repair of the lift and result in severe injury and/or damage to the lift.

5. Follow OSHA lock-out/tag-out procedures. Disconnect and tag all electrical and/or other power sources to prevent an unplanned or unexpected actuation of the lift.
6. Once inspection or work is complete, reverse steps 1-5 above to raise the lift off the maintenance device(s) and place them back into their designated storage position(s).



DANGER !

HIGH VOLTAGE!! – Disconnect and/or lock out the electrical supply to the power unit prior to any installation or maintenance being performed.

LIFT BLOCKING INSTRUCTIONS



DANGER!

To avoid personal injury, **NEVER** go under the lift platform until the load is removed and the Lift is securely blocked in the Raised position.

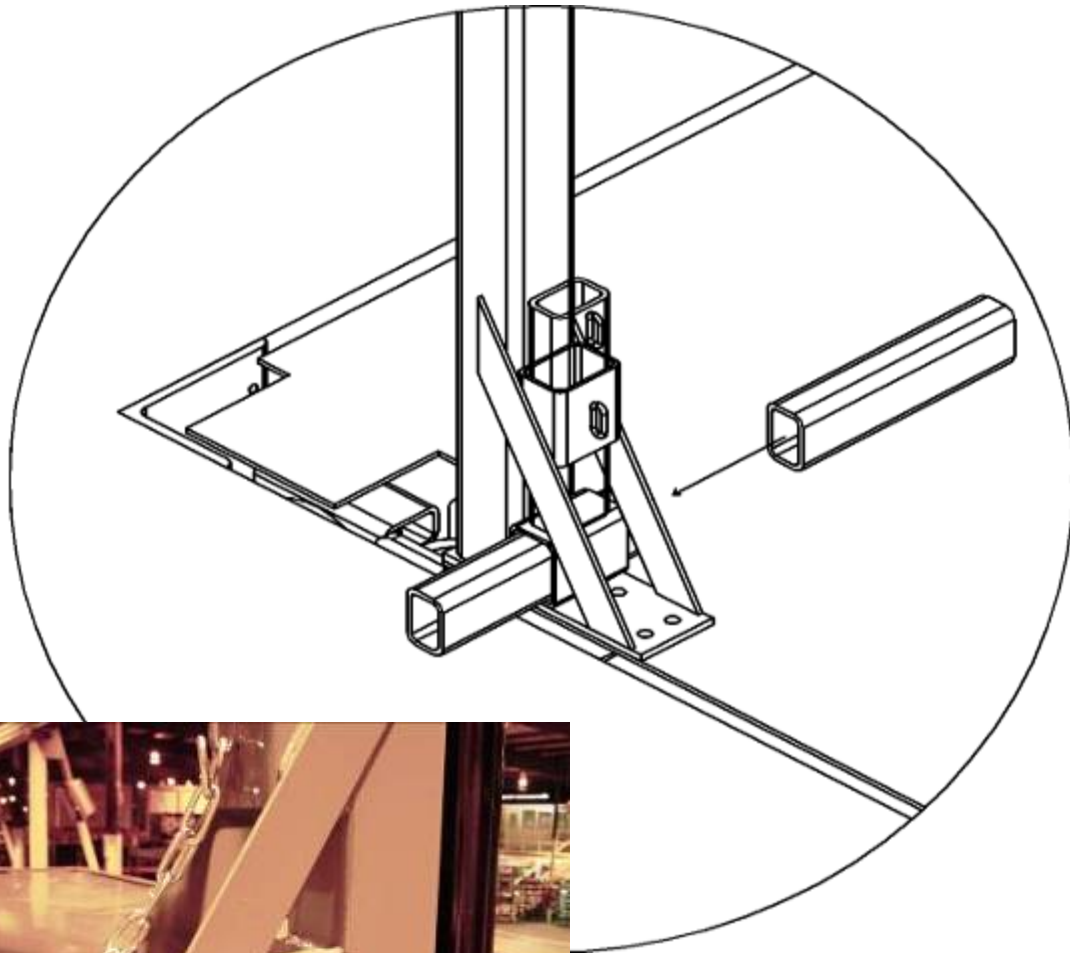

Figure 12 Maintenance Devices

INSTALLATION INSTRUCTIONS

GENERAL (Reference the General Arrangement Drawing – sent separately)

Please refer to the General Arrangement (GA) or Record Drawings that have been shipped with the lift. These drawings have notes and measurements that should be checked before installation of the lift. The drawings will show how the lift should be arranged and how it should be installed specifically for this application. The installation may begin only after all of the measurements have been checked and are correct (floor-to-floor distances, pit depth, upper level opening, overhead clearances, etc.).

NOTE: All illustrations contained in this manual are for reference purposes only. Specific applications and site conditions may require different anchoring and bracing procedures. The ultimate responsibility for the anchoring and bracing rests with the installation crew.

A. PIT MOUNTING (Reference Fig.13)



DANGER!

Do not install the lift in a pit unless it has a bevel toe guard or other approved toe protection. A shear point can exist which can cause severe injury to the foot.

Lift platforms traveling below floor levels may create openings, and the shape of the load and how the load is arranged on the lift may create a toe hazard as the load passes the top edge of the pit. Both situations may require guarding in accordance with Federal Regulations. Any such guarding must be installed prior to operating the lift.

1. The pit in which the lift is installed is the responsibility of the contractor or owner.
2. Optimally, the overall length and width should be 2" minimum longer and wider than the lift platform. Depth should be the lowered height plus ½".
3. Check the chase entrance into the pit. The diameter should be 3".

INSTALLATION INSTRUCTIONS

80119140

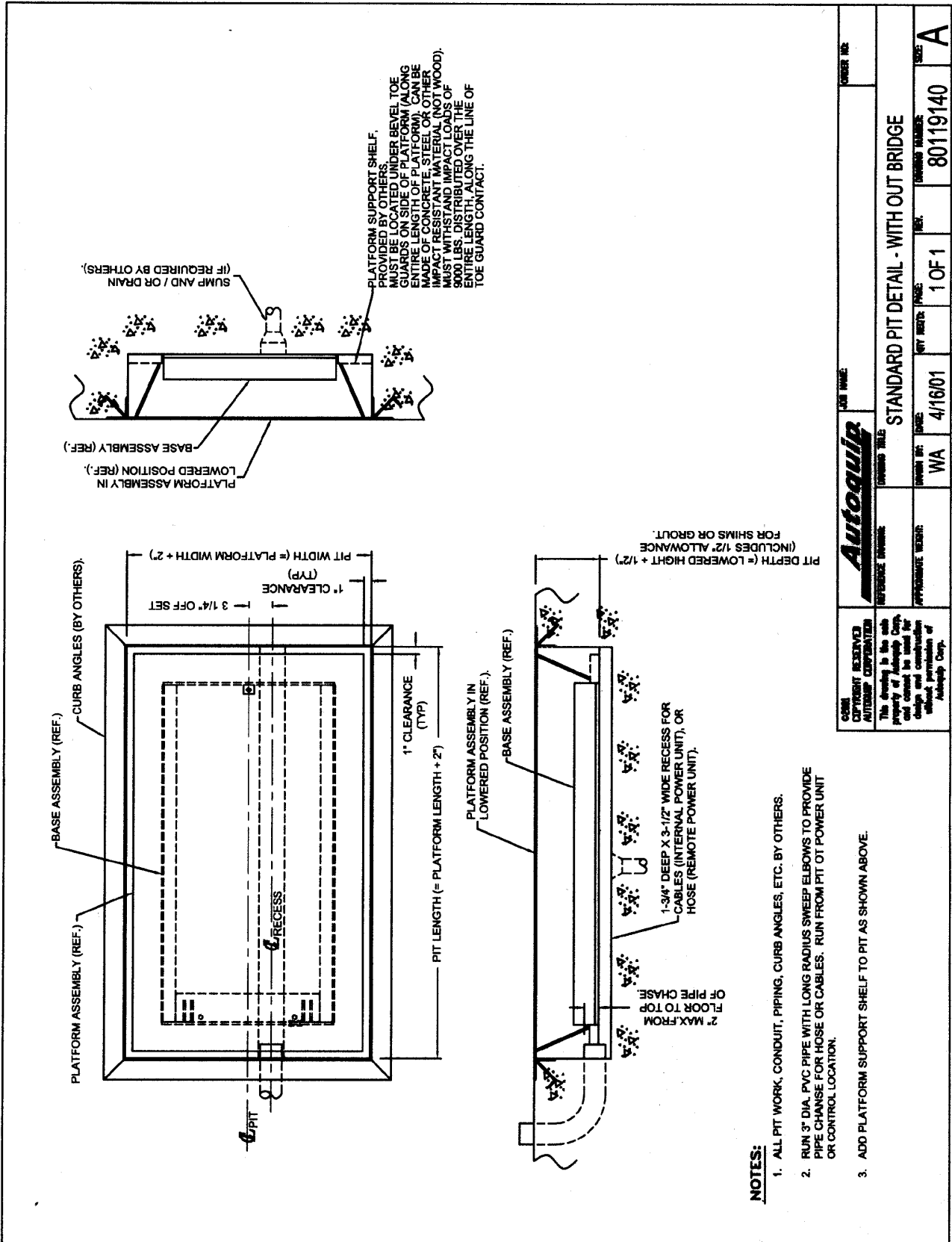

Figure 13 Generic Pit Drawing

Autoquip <small>Autoquip Corporation</small>	<small>DATE:</small> 4/16/01	<small>REV.:</small> 1 OF 1	<small>ORDER NO.:</small> 80119140
	<small>APPROXIMATE WEIGHT:</small>	<small>QTY. ORDERED:</small>	<small>ORDER NO.:</small> A
<small>FORM COPYRIGHT RESERVED BY AUTOQUIP CORPORATION</small>	<small>REFERENCE NUMBER:</small>	<small>STANDARD PIT DETAIL - WITH OUT BRIDGE</small>	<small>FORMING NUMBER:</small>
<small>This drawing is the sole property of Autoquip Corp. and cannot be used for design and construction without permission of Autoquip Corp.</small>	<small>DATE:</small>	<small>REV.:</small>	<small>ORDER NO.:</small>

INSTALLATION INSTRUCTIONS

B. REMOTE POWER UNIT INSTALLATION (Reference Figure 14)

1. The power unit is to be located in an area protected from the elements and should be installed prior to the lift to facilitate lift operation during installation into the pit.
2. The power unit should be located in an approved location so as to not ignite any potential vapors that collect near the floor – usually a minimum of 18” off the floor. **Refer to applicable local Building & Safety Codes.**
3. The electrical work is to be done in accordance with local codes by a qualified electrician. See the “Maintenance” section for the standard wiring diagram.
4. If permanent electrical work is not complete, some means of temporary power with an on/off device for the motor will be required.
5. Fill the reservoir with oil per instructions in the “Maintenance” section.

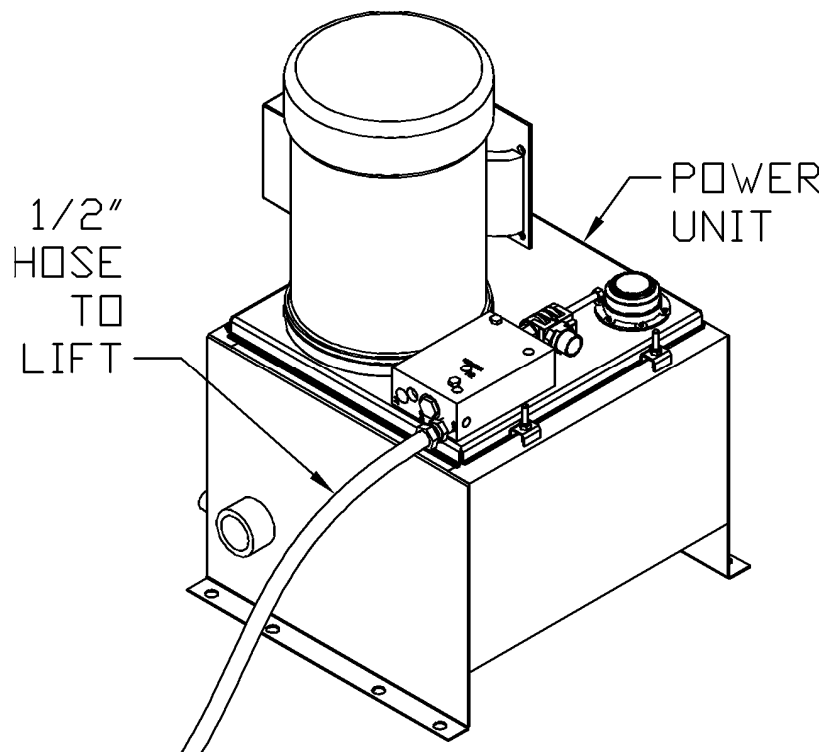

Figure 14 Standard Power Unit – 5HP/230VAC/1ph

INSTALLATION INSTRUCTIONS

C. LOWERING and INSTALLING THE LIFT (Reference Figure 15)



CAUTION!

Precautions should be taken to prevent the introduction of contaminants such as dirt or other foreign material into the system through open fittings, pipes or disassembled components. Contamination will ruin the hydraulic system.

1. Using $\frac{3}{4}$ " 10 UNC eyebolts and a chain spreader, place the lift into the pit as illustrated in **Figure 15** using the lifting eye provisions included (lifting eyes by installer).
2. Make temporary hose connections with high-pressure hose (3,500 PSI) to allow the lift to be operated when it is set in the pit (see chart below).

Hydraulic Piping/Hose Size

Up to 25 feet	$\frac{1}{2}$ " ID
26 feet to 50 feet	$\frac{3}{4}$ " ID
Over 50 feet	1" ID

3. Remove the shipping bolt and eye bolts from the lift and hydraulically raise the platform. Failing to remove the shipping bolts before operation will cause permanent damage to the lift.
4. Check the routing of the temporary hydraulic lines to assure that the hose is clear of legs, base frame, and platform when lift is in the lowered position.
5. Make positioning adjustments of the lift to align the platform with a one-inch clearance around the edges of the pit. Raise and lower the platform several times to confirm the alignment is correct.
6. Raise the platform and engage the maintenance device (see "Lift Blocking Instructions" section).
7. Lag down the base frame in the holes provided. Lag bolts should be able to withstand 2000 lbs. minimum upward pull at each corner.
8. Replace the temporary hose connections with permanent hydraulic lines from the power unit (refer to **Hydraulic Piping/Hose Size** chart above). The female end connection on the lift base frame is $\frac{1}{2}$ " NPT.

INSTALLATION INSTRUCTIONS

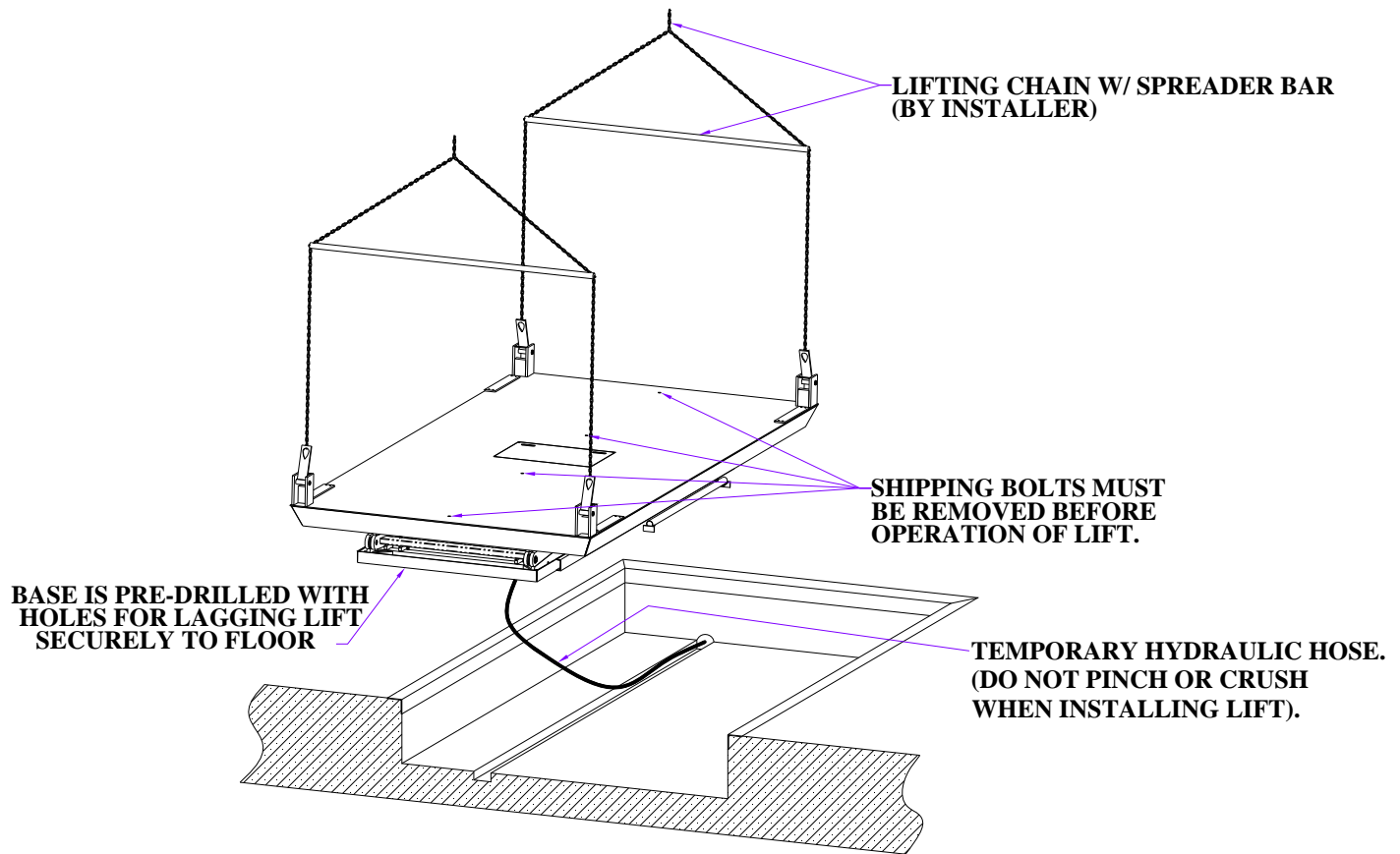

Figure 15 Generic Dwg - Lifting and Handling

D. LEVELING THE LIFT TO GRADE

1. The platform top should be solid and flush with the pit curb angles. The pit depth includes $\frac{1}{2}$ " added to the lowered height of the lift for leveling purposes (refer to **Figure 13**).
2. Fully lower the lift platform into the pit and check for proper height. Adjustable landing legs have been included to facilitate
3. Shims and/or grout must be placed under the entire base frame assembly and the platform support members to support the platform top at grade level. **DO NOT "spot" shim under the base frame!** Shims and/or grout must be able to support the lift base frame while loaded at full rated lifting capacity and rollover load.

INSTALLATION INSTRUCTIONS

E. ATTACHING THE CANOPY POSTS (Reference Figure 16)

Items needed from the crates for this step:

<u>Qty</u>	<u>Description</u>
4	Square Tube Canopy Posts w/Maintenance Device
16	1/2"-13 x 1" Long Hex Head Bolts, Grade 5
16	1/2" Flat Washers
16	1/2" Lock Washers

1. Bolt the four (4) posts into place as shown with the hardware provided. Tighten bolts using 50 ft-lbs of torque.

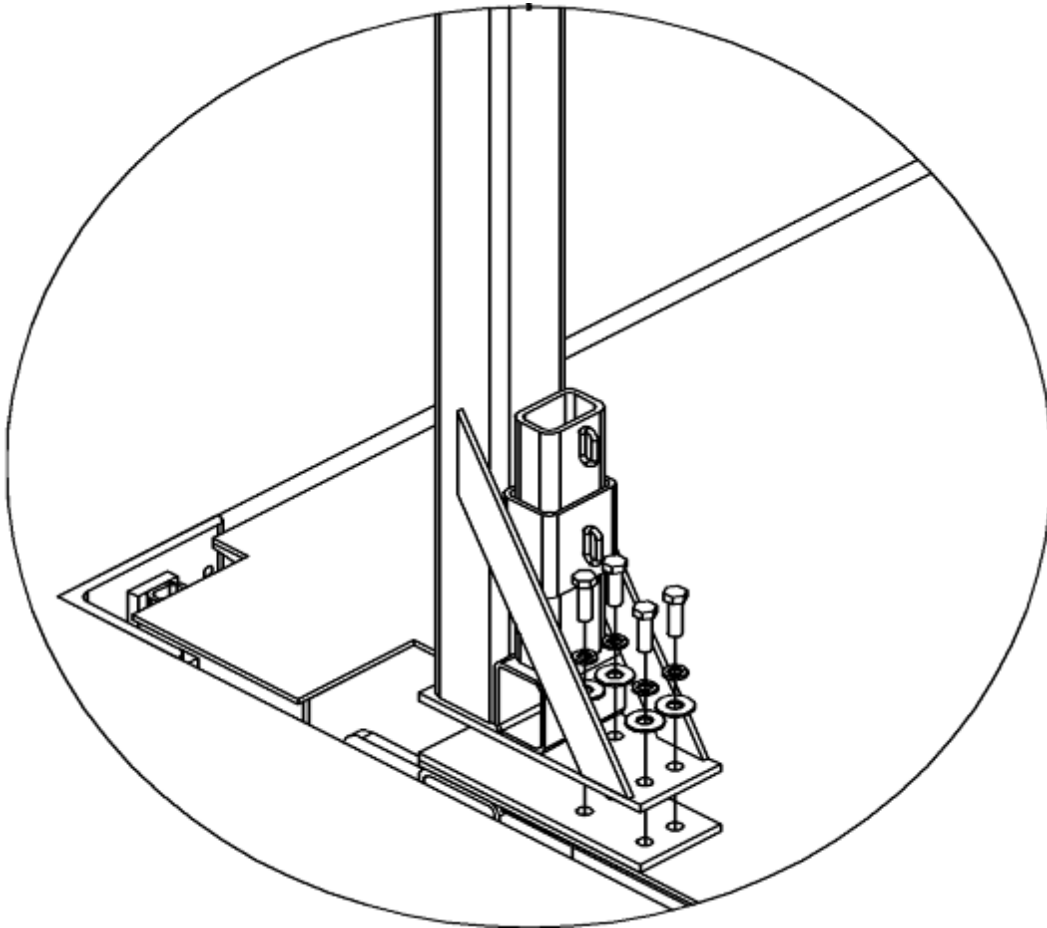

Figure 16 Attaching Canopy Posts – Typical (4) Places

INSTALLATION INSTRUCTIONS

F. ATTACHING THE CANOPY DECK (Reference Figures 17 & 18)

1. Using nylon straps / hooks and lifting eye provisions in the deck surface, raise the upper/canopy over the four (4) canopy posts, sliding the square collars located beneath the deck over and onto the four posts. Make sure that the deck orientation (location of access hatch – if applicable) matches the GA Drawing and that all four posts are engaged into the platform collars.
2. Lower the lift to full down position to level the canopy with the garage floor. Do not weld canopy to posts yet, further adjustments to the canopy must be made.
3. With the carriage leveled and in the fully lowered position, use the overhead hoist or crane to lift and adjust the slope of the top canopy to be flush with, and match the grade of, the surrounding garage/parking floor (reference **Figure 17**). Weld per General Arrangement drawing once complete.

INSTALLATION INSTRUCTIONS

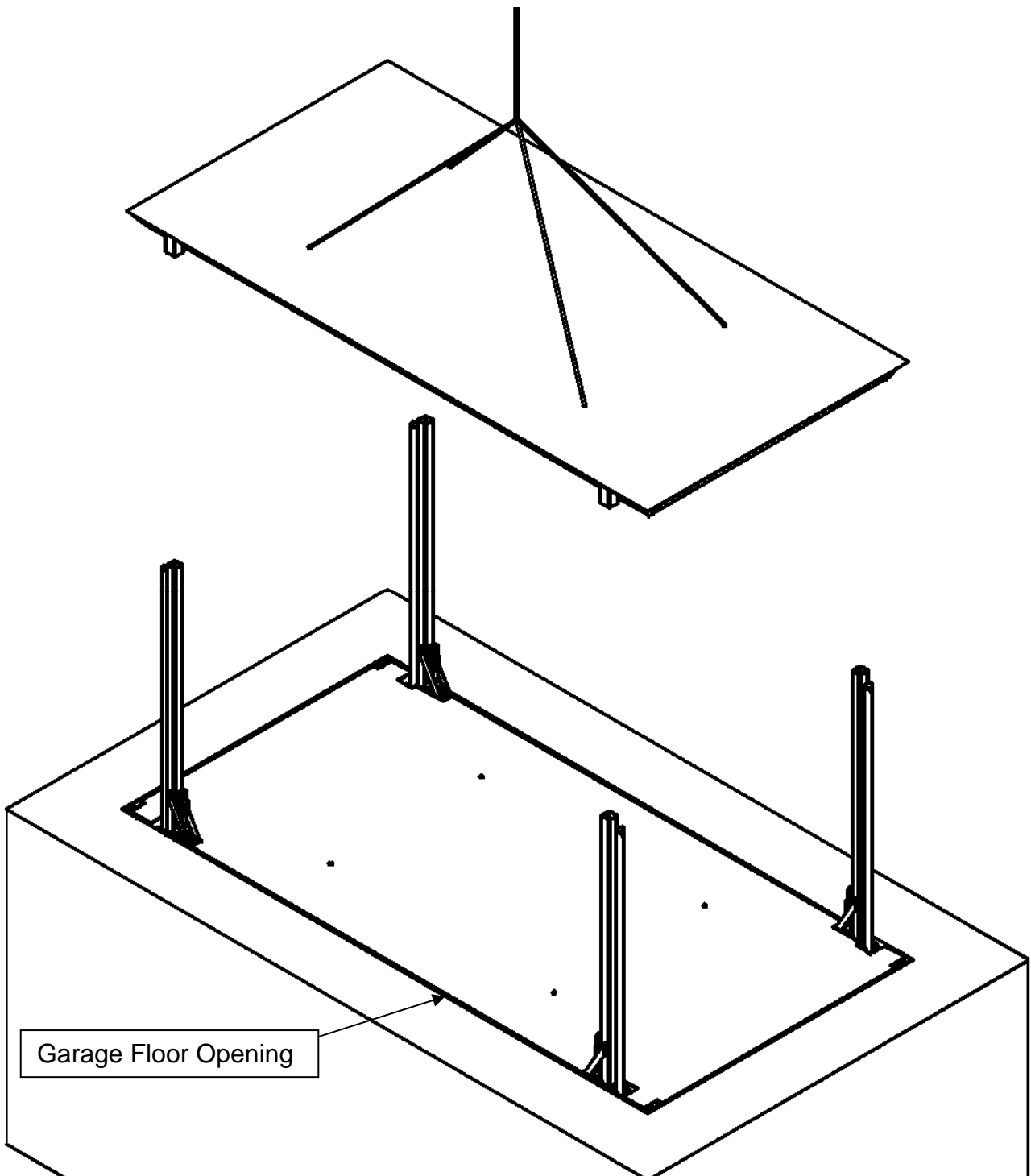

Figure 17 Canopy Assembly

INSTALLATION INSTRUCTIONS

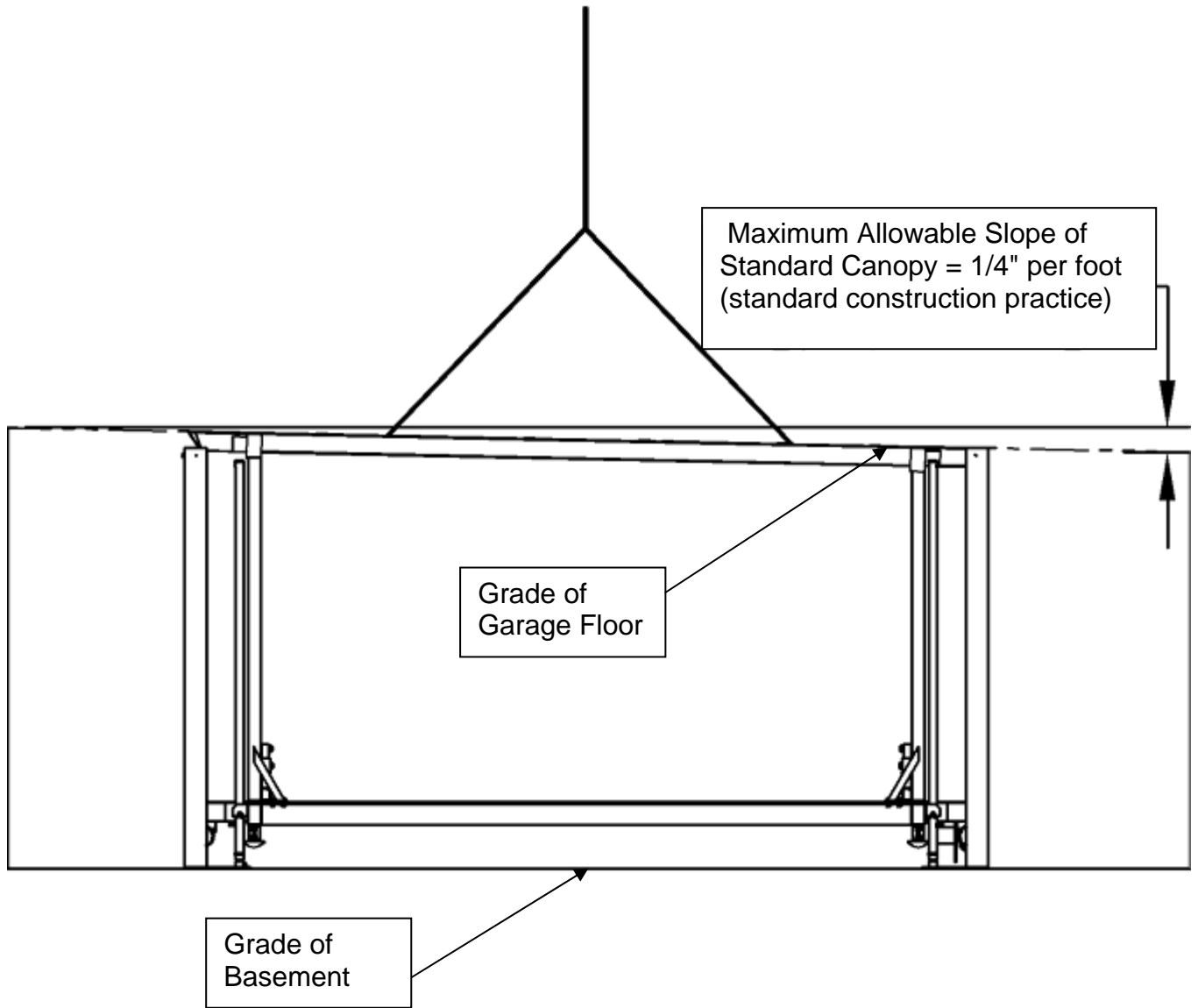

Figure 18 Adjusting Canopy to Match Grade of Garage Floor (Side View)

INSTALLATION INSTRUCTIONS

G. ADJUSTING THE UP-STOP VALVE (Reference Figure 19)

The up-stop system can be adjusted to modify vertical travel by:

1. Loosen the holding nuts on either side of the adjustable striker bolt.
2. Screw the adjustable striker bolt in to shorten the lift travel.
3. Retighten the holding nuts.

Note: The striker bolt should not be adjusted “out” to increase the lift travel. This will over-travel the lifting rams and may cause damage to the system.

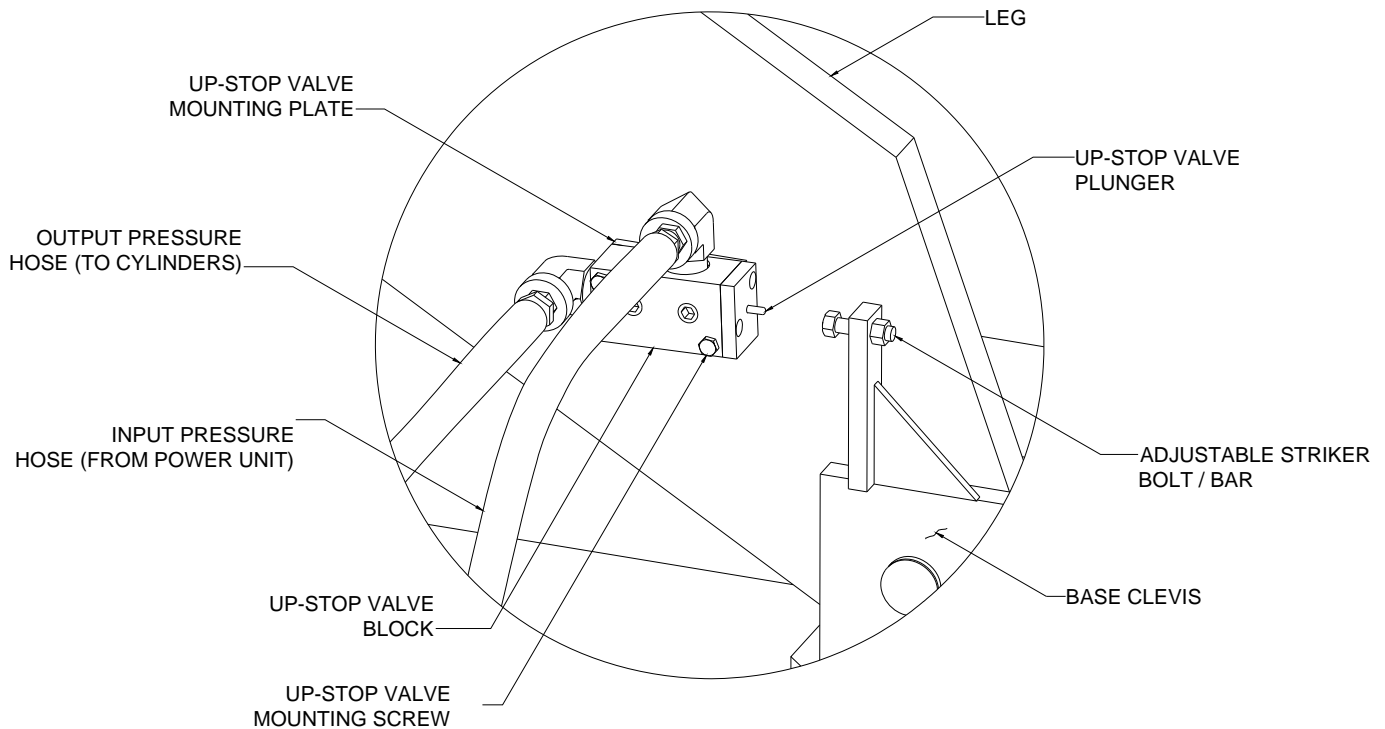

Figure 19 Up-Stop Valve System

INSTALLATION INSTRUCTIONS

H. PERMANENT ELECTRICAL INSTALLATION (See job-specific schematic)

A generic electrical schematic for a 4-post Parking Lift installation has been included in the General Maintenance section of this manual. In addition, a job-specific schematic has been shipped separately (usually inside the electrical control panel) for reference by the electrical service provider. Refer to this schematic and follow all applicable NEC requirements throughout the electrical installation process.

Autoquip provides all the electrical control and signal devices. All required wire, conduit, and main disconnect for field wiring is supplied by others. Unless specifically included in the contract, the mounting and wiring of control and signal devices is the user's responsibility.

MAIN DISCONNECT:

This should be a fused type disconnect which is to be located within ten (10) feet of the main control panel. THIS ITEM IS NOT SUPPLIED BY AUTOQUIP AND IS REQUIRED BY THE NEC (National Electrical Code), typically with the ability to be locked per OSHA lock-out, tag-out procedures.

MAIN CONTROL PANEL:

This panel is supplied and shipped loose by Autoquip and all electrical components will be tied into this panel. Mount this panel as close to the power unit as possible and in accordance with the requirements of local codes and the NEC, connect primary voltage to the motor and secondary voltage to the control valves.

PUSH BUTTON STATIONS:

Autoquip supplies one (1) Pushbutton for each installation (under normal conditions), and optional emergency stop (E-Stop) "panic" button(s). All operator pushbutton stations are wired to the control panel with secondary voltage by others.

LIFT LEVEL LIMIT SWITCHES (When ordered):

Limit switch(es) have been attached to be field wired and adjusted to sense and stop the lift when the lower deck reaches the upper position and/or lower position – when door interlocks are purchased for lower level access doors.

DOOR STATUS SWITCHES (When Ordered):

Ship-loose limit switch kit(s) are sent to field install to sense whether doors are opened or closed. These limit switches need to be wired to the main control panel to prevent lift operation if any door leading into the lift area is ajar.

INSTALLATION INSTRUCTIONS

DOOR SOLENOID LOCKS (When Ordered):

Ship-loose, electrical solenoid kits are supplied for doors leading into the lift area and are mounted in such way as to lock a closed door any time the lift is in motion.

PHOTO-EYE SENSORS (When Ordered):

Photo Eye sensors & reflectors can be shipped loose for field locating, installing & wiring at either elevation for one of two reasons:

- a. sense that there is a vehicle on the top deck and prevent lift from being raised unless the vehicle is removed.
- b. sense along an entire edge of the lift and stop lift operation if any object gets close enough to the edge to break the photo beam.

MANUAL RESET PANEL (When Ordered):

A manual reset panel and button can be placed near a remote (lower level) door to force the operator to inspect any door which may have been opened into the lift area and caused the lift to stop.

J. FINAL TEST RUN & ADJUSTMENTS



DANGER!

Never go under an unsupported platform! To avoid personal injury or death, be sure the platform has been blocked from underneath! See “Blocking Instructions.”

NOTE: For lifts purchased with “press and release” (call-send) pushbutton contacts, you will have to stop the lift movement (both up and down) with the Emergency Stop “panic” button.

1. Check oil level of reservoir with the lift in the fully lowered position. Oil should be 1” to 1 ½” below the top of the reservoir tank. (See the “Maintenance” section for oil specifications.)
2. Activate the down push button and lower the lift. Is the carriage stopping level and flush with the basement/lower elevation?

INSTALLATION INSTRUCTIONS

3. All doors accessing the lift area must have door status switches and interlocks to prevent the lift from operating if a door is left open. A door should remain closed & locked while the lift is in motion.
4. Raise the lift 3-6 feet from the fully lowered position. Is everything okay? Any unusual noises?
5. If you are satisfied with the alignment and performance, run the carriage higher, continuing to check the clearance and smoothness of operation.
6. Ensure that the carriage remains level throughout the lift travel.
7. Slowly raise the carriage to the upper/garage level. Be sure that 1" clearance is present between the carriage and all building structures and other site constraints (floor openings, doors, building columns/beams, piping, etc.).
8. Lower the lift a few feet and bring it back up. Run against the up-stop valve and see if the front of the carriage is flush with the adjacent floor surface. If the carriage is above or below the floor, adjust up-stop valve as needed.
9. Run the system through its paces with the complete electrical system. Make all necessary adjustments to the interlocks, gate status switches, and any photo-eye sensors to ensure proper operation of the lift and its safeties as required by the schematic.

K. BLEEDING AIR FROM THE SYSTEM

1. Bleed any air which may have been entrapped in the hydraulic system by raising the lift to approximately 50% of its full travel, then lower back down completely. Repeat this process five or six times.
2. Raise and block the lift (See "Lift Blocking" section).
3. Remove (bleed) any remaining air which may have trapped in the cylinders by slowly loosening using the bleed screws located on the rod end of the cylinders until air is heard escaping. Tighten bleeder screws back down when oil begins to escape. Be extremely careful and loosen screws slowly, the cylinders are under high pressure and could spray oil.

INSTALLATION INSTRUCTIONS

L. INSTALLATION WRAP-UP

1. Touch-up the paint as needed.
2. Attach all shipped-loose Decals & Warning Labels per **Figure 1** of this manual (Contact an Autoquip Customer Service Representative if you are missing any required labels).
3. Install the plastic plugs provided in all lifting eye holes (**Figure 20**).
4. Clean up area.
5. Train all potential operators to use the lift and to follow all safety procedures.
6. Ensure that the appropriate person signs off on the Warranty Registration Card and receives one Owner's Manual per lift.

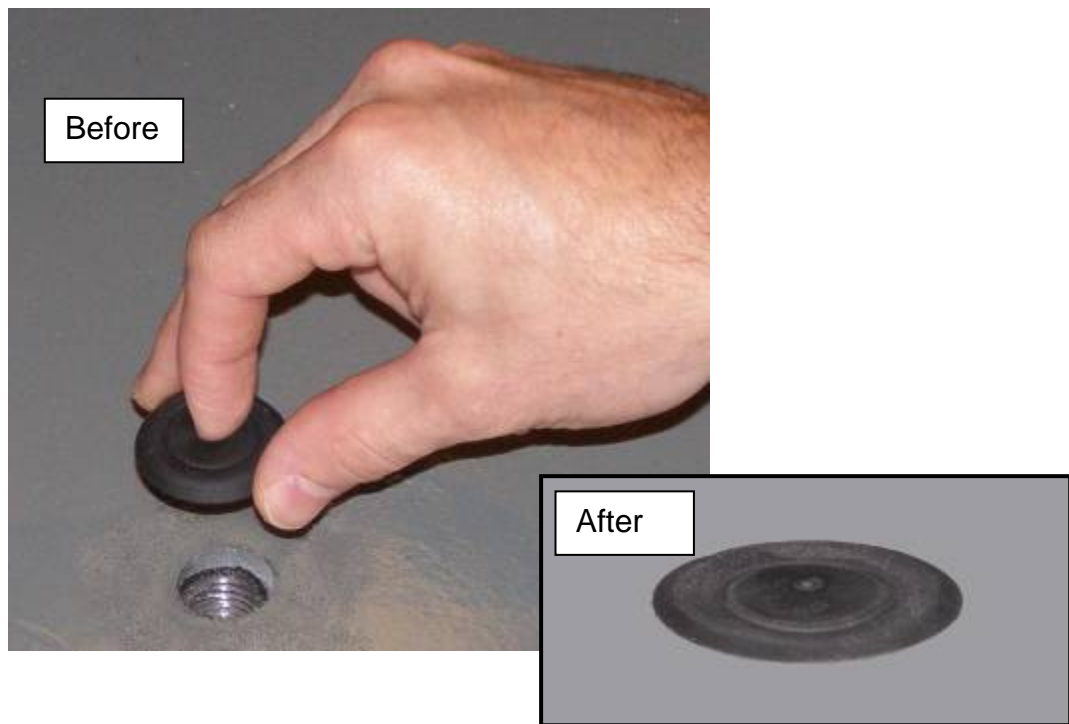

Figure 20 Plugging Holes in Deck



WARNING!

All DANGER, WARNING, and CAUTION labels and informational decals and plates must be intact and in place on the lift. Contact an Autoquip representative if labels are missing or damaged.

OPERATING INSTRUCTIONS



WARNING!

Familiarize yourself with operators manual before operating this lift.



DANGER!

To avoid personal injury or death, do not operate this equipment with damaged, substandard, defective, or missing parts. Contact a local Autoquip service representative if a deficiency is found.



WARNING!

All gates and/or doors accessing the Lift are electrically interlocked and must be closed to permit operation the lift. Do not operate unit with doors open or with the interlocks or other safety devices “defeated” (bypassed)! Serious injury or death could result.

UP

When the “UP” button is pressed, and all interlocks are closed and all safety circuits unbroken, the coil of the motor starter (M1) will close the line contacts of M1 permitting the electric power to be applied to the motor.

The rotating motor shaft is mechanically coupled to a positive displacement gear pump. This pump will rotate, assuming proper motor rotation direction, and it draws oil from the reservoir. The oil is pressurized, causing flow through the check valve, and forces it out to the cylinders through a high pressure hose. The hydraulic cylinder is attached to structural members of the lift causing the scissor mechanism of the legs to open as the cylinder rod extends.

The lift will continue to move upward as long as the motor is running. When the lift deck reaches the upper level, the adjustable hydraulic Up-Stop Valve located in the base of the lift closes and blocks further flow of oil to the cylinders from the power unit.

When the motor stops, the hydraulic oil in the system is held in place by the spring-loaded check valve that has returned to its seat, thereby blocking the backflow through the control valve. The platform will maintain its position at the upper floor level.

OPERATING INSTRUCTIONS

DOWN

Pressing the DOWN push-button applies control power to the down solenoid coil which causes the core plunger to move outward, allowing the down valve to open and the pressure-compensated down speed regulator to regulate the degree of the valve opening. This is dictated by the weight of the load placed on the lift. The lift will come to a stop when it reaches the lower floor level. At this point, there is no pressure remaining in the hydraulic system and flow through the down valve ceases, though the valve remains open.

NOTE: The motor does not operate during downward travel.

EMERGENCY STOP

(when ordered)

Press the red emergency stop button to stop all travel of the lift at any time. After the emergency stop button has been reset, any level button may be pressed to continue travel.

The emergency stop button will interrupt all electrical control functions when it is activated. Movement of the lift will cease, regardless of its direction.

KEY SWITCH OR KEY PAD STATION

Use the security key, or security code, to turn the control system "On". These stations are shipped loose and wired in the circuit between the control panel and the operator pushbutton station by others to prevent unauthorized operation of the lift.

NOTE: For liability reasons, It is recommended that the key or code NOT be left in or near the station.

ROUTINE MAINTENANCE



DANGER!

To avoid personal injury or death, all maintenance procedures described in this section should only be performed by qualified service personnel.



DANGER!

To avoid personal injury or death, do not operate this equipment with damaged, substandard, defective, or missing parts. Contact a local Autoquip service representative if a deficiency is found.



WARNING!

To avoid serious injury or death, **GUARDS, INTERLOCKS, and SAFETY DEVICES** must be restored to correct operation when installing parts or making repairs.

MONTHLY INSPECTION:

1. Check oil level (see oil recommendations in this section) and add appropriate oil when necessary.
2. Check for any visible leaks. Correct as necessary.
3. Check any unusual noise when it occurs. Determine the source and correct as necessary.
4. Check the snap rings at all rollers, if not in place, and/or secure, replace or repair immediately.
5. Check all rollers for signs of wear. Replace as necessary.
6. Do not grease roller or axles; they have lifetime-lubricated bearings.
7. Check all wiring for looseness or wear. Repair at once.

OIL REQUIREMENTS:

Change oil yearly, or more frequently if it darkens materially or feels gummy or gritty. **Do not use hydraulic-jack oil, hydraulic fluids, brake fluids, or automatic transmission fluid.**

ROUTINE MAINTENANCE

Oil Viscosity Recommendations

Environment (Ambient Temperatures)	Recommended Oil
Indoor location, variable temperatures (30 - 100° F)	10W30 or 10W40 Multiviscosity motor oil
Indoor location, consistent Temperatures (70° F)	SAE-20W motor oil
Outdoor location, (-10 - 100° F)	SAE 5W30 Multiviscosity motor oil
Cold-storage warehouse (10 - 40° F)	5W30 Multiviscosity motor oil
Freezer (-40° F to 0° F)	Consult Factory

NOTE: All oils above are detergent type.

NOTICE

It is very important to use the proper oil in the operation this lift !!

DO NOT USE:

- Automatic Transmission Fluid (ATF)
- Hydraulic Jack Oil
- Hydraulic Fluids
- Brake Fluids

OIL CAPACITY

Reservoir capacity for the steel “vertical mount” tank is approximately 11 gallons.

Reservoir capacity for the “horizontal mount” tank is approximately 22 gallons.

The oil level in the reservoir should be 1” to 1 ½” below the top of the reservoir with the lift in the fully lowered position.

GENERAL MAINTENANCE

CYLINDER REPACKING (Reference Figures 21)

1. Raise the lift to its full height and block securely. See “Lift Blocking Instructions”.
2. Hold the “DOWN” control for several seconds to make sure pressure in the lines is bled down.
3. Disconnect the ram hose at the power unit end and insert into the oil-fill hole of the reservoir.

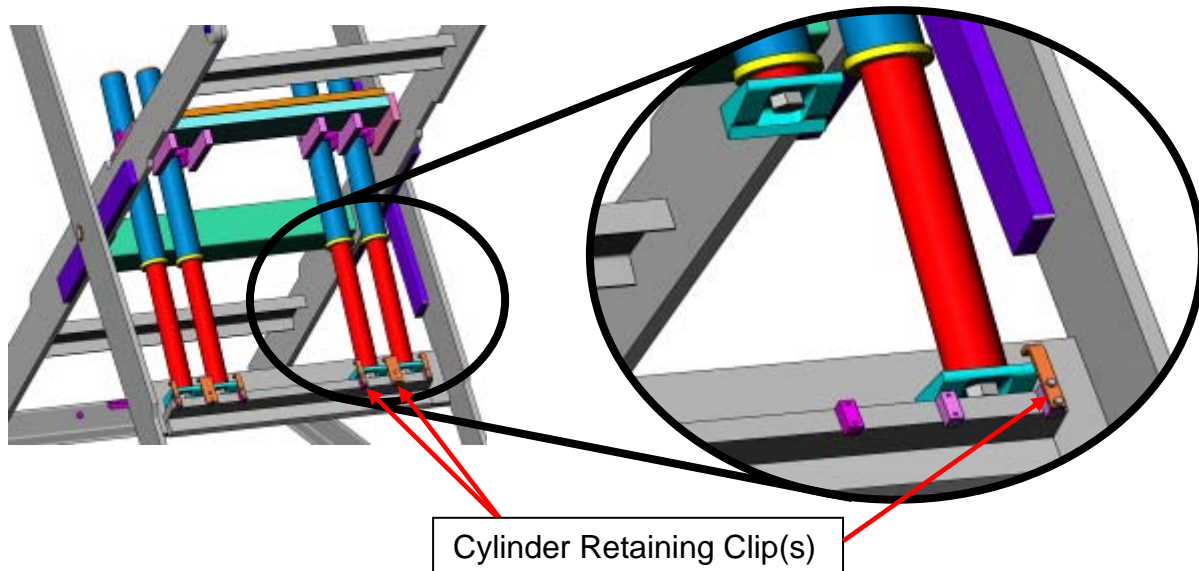

Figure 21a Cylinder Removal

4. Remove the thrust angle clip from the ram (plunger) end of the cylinder and force the ram slowly back to its fully closed position to push oil back into the reservoir. **Do not submerge the hose end in the reservoir or you will draw oil back into the cylinder when removing the ram.**

GENERAL MAINTENANCE

5. Pull the ram all of the way out of the cylinder. The ram is extremely heavy, so support it carefully so that it does not drop when it clears the cylinder end. Lay it down in a safe, clean place. Some oil may drip from the end of the cylinder so have waste cloth or paper beneath the lift to protect the floor.

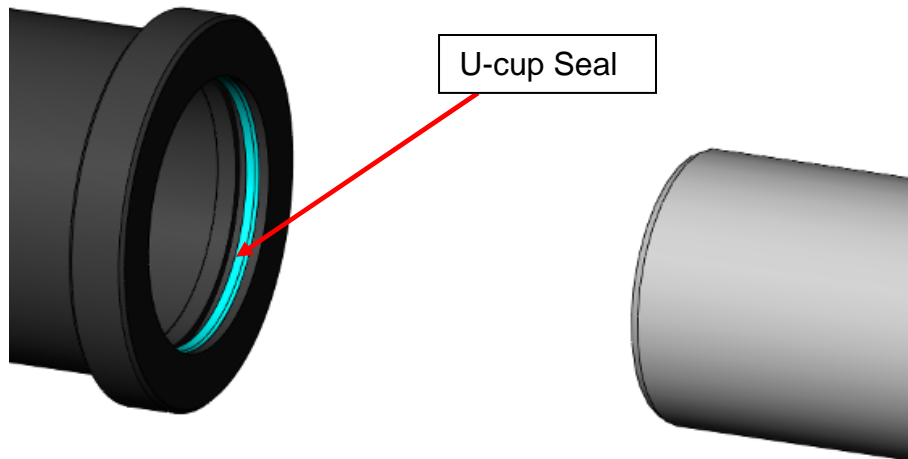

Figure 21b Cylinder Removal

6. Remove the U-cup seal.
7. After all of the internal components are removed, use a bright light to inspect the inner walls of the barrel. Use a cylinder hone to remove any apparent nicks or scratches. Clean and flush the barrel after honing.
8. Inspect the ram and seal groove for nicks or scratches that could affect the seal or barrel walls; remove as necessary.
9. Clean the groove thoroughly and install the new seal. Make sure the open face of the seal is toward the closed end of the cylinder as shown in **Figure 21c**.

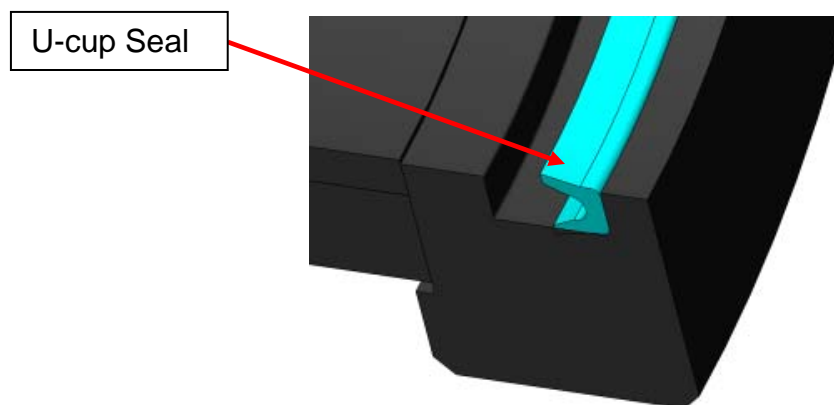

Figure 21c Cylinder Removal

GENERAL MAINTENANCE

10. Clean the ram of all foreign materials.
11. Liberally lubricate the ram and seal with CLEAN grease or oil.
12. Insert the ram carefully back into the cylinder taking precaution against pinching or tearing the seal ring.
13. Reinstall the clip over the thrust angle.
14. Reconnect the cylinder hose.
15. Restore the oil level.
16. Loosen the bleeder plug at the top end of the ram casing and operate the pump to remove trapped air from the ram. When clear oil appears, tighten the plug and raise the lift slightly to remove the maintenance locks.
17. Cycle the lift 10 – 15 times.
18. Check the oil level.
19. Clean the oil fill breather cap.
20. Clean up any debris and/or spilled oil from the area.

PIPE THREAD SEALANT

Loctite PST #567 pipe thread sealant or equivalent is recommended. **Do not use Teflon tape.** Tape fragments can cause malfunctioning of the hydraulic system.

GENERAL MAINTENANCE

VELOCITY FUSE REPLACEMENT



DANGER!

Do not attempt to remove the velocity fuse until the lift is securely supported with the maintenance locking devices and all hydraulic pressure has been removed from the lifting cylinders and hydraulic hoses. Failure to follow these instructions could result in personal injury or death!

Never attempt to take a velocity fuse apart and repair it. These are precision devices that are factory assembled under exacting conditions. Velocity fuses should always be replaced.

1. The arrow on the exterior surface of the velocity fuse shows the direction of the restriction to the oil flow. The arrow should always point away from the cylinder.
2. **Do not use Teflon tape on the threaded connections of a velocity fuse.** Tape fragments can cause malfunctioning of the fuse.
3. Check all fitting connections for hydraulic leaks and tighten as necessary.

HOSE ORIENTATION

To prevent damage to the cylinder hose and possible failure of lift, it is necessary to establish a correct hose shape and pattern of movement as follows:

1. Raise the lift to its full height and block securely. See "Lift Blocking Instructions".
2. Install one end of the new hose to the cylinder elbow fitting.
3. Since the hose is fixed at both ends, it is possible to put a twist in the hose that will allow it to describe the same pattern each time the lift is operated. This twist will allow the hose to travel about half way between the cylinder on the right side and the inner leg on the right side.
4. Lower the lift carefully and check to see that the hose is free and clear of the cylinder and the inner leg assembly. If not, twist the hose in the direction necessary to clear it of any obstruction and then lock the swivel fitting securely.

GENERAL MAINTENANCE

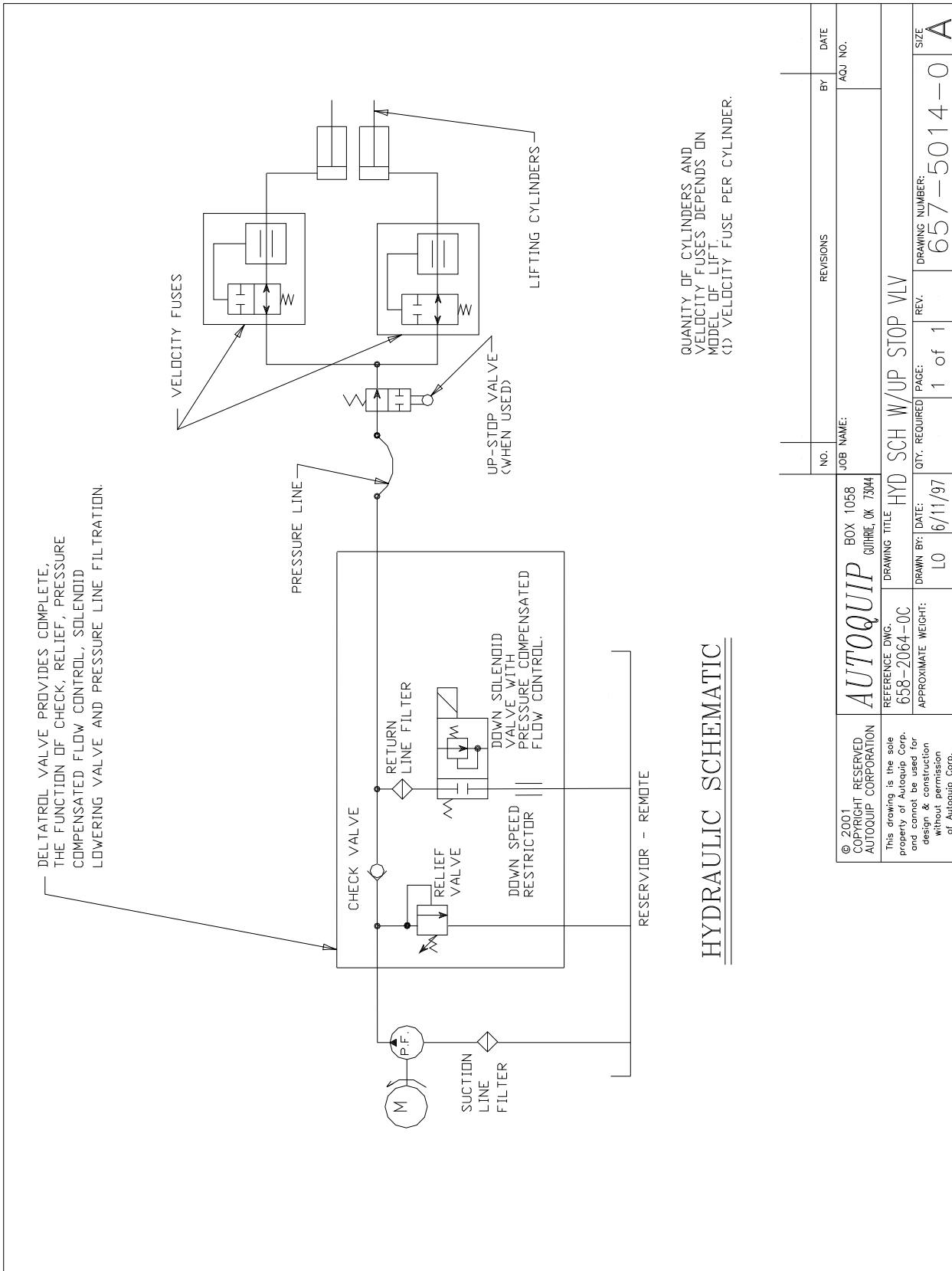

Figure 22 Generic Hydraulic Schematic

GENERAL MAINTENANCE

POWER UNIT



DANGER!

HIGH VOLTAGE!! Disconnect and/or lock out the electrical supply to the power unit prior to any maintenance being performed.

1. The “vertical” unit utilizes a heavy duty 5 HP/230 Volts/60 hertz/single-phase motor coupled to a high-pressure positive displacement gear pump, and *Autoquip Corporation’s* patented Deltatrol valve assembly. It is also available with a 5 HP/208, 230, or 460 Volts/60 hertz/3 phase motor as an option to double oil flow – and thereby double lift speed.
2. The following should be referenced in connecting the standard heavy-duty motors to power sources. Remember that heavy wire must be used all the way to the power source.

Power Unit	115 Volts	208 Volts	230 Volts	460 Volts
Standard Three Phase	N/A	16 AMPS	15.2 AMPS	7.6 AMPS
Standard Single Phase	58 AMPS	N/A	24.5 AMPS	N/A

NOTE: All amperage draws shown are full-load amperages.

GENERAL MAINTENANCE

UP-STOP VALVE

The up-stop valve is bolted to a mounting plate that is permanently welded near the end of the scissors leg on the clevis end of the lift. A mechanical plunger is located on the end of the valve which, when depressed, blocks the flow of oil until physically released. An adjustable striker bolt is mounted to a plate that is welded to the base frame, which is also at the clevis end of the lift. As the lift travels upward, the scissors leg and up-stop valve assembly swings into the adjustable striker bolt until the up-stop plunger is depressed and thereby blocking the flow of oil to the cylinders. Once blocked, any further oil pumped from the power unit will pass over the relief back to the tank.

The up-stop system can be adjusted to modify vertical travel by:

4. Loosen the holding nuts on either side of the adjustable striker bolt.
5. Screw the adjustable striker bolt in to shorten the lift travel.
6. Retighten the holding nuts.

Note: The striker bolt should not be adjusted “out” to increase the lift travel. This will over-travel the lifting rams and may cause damage to the system.

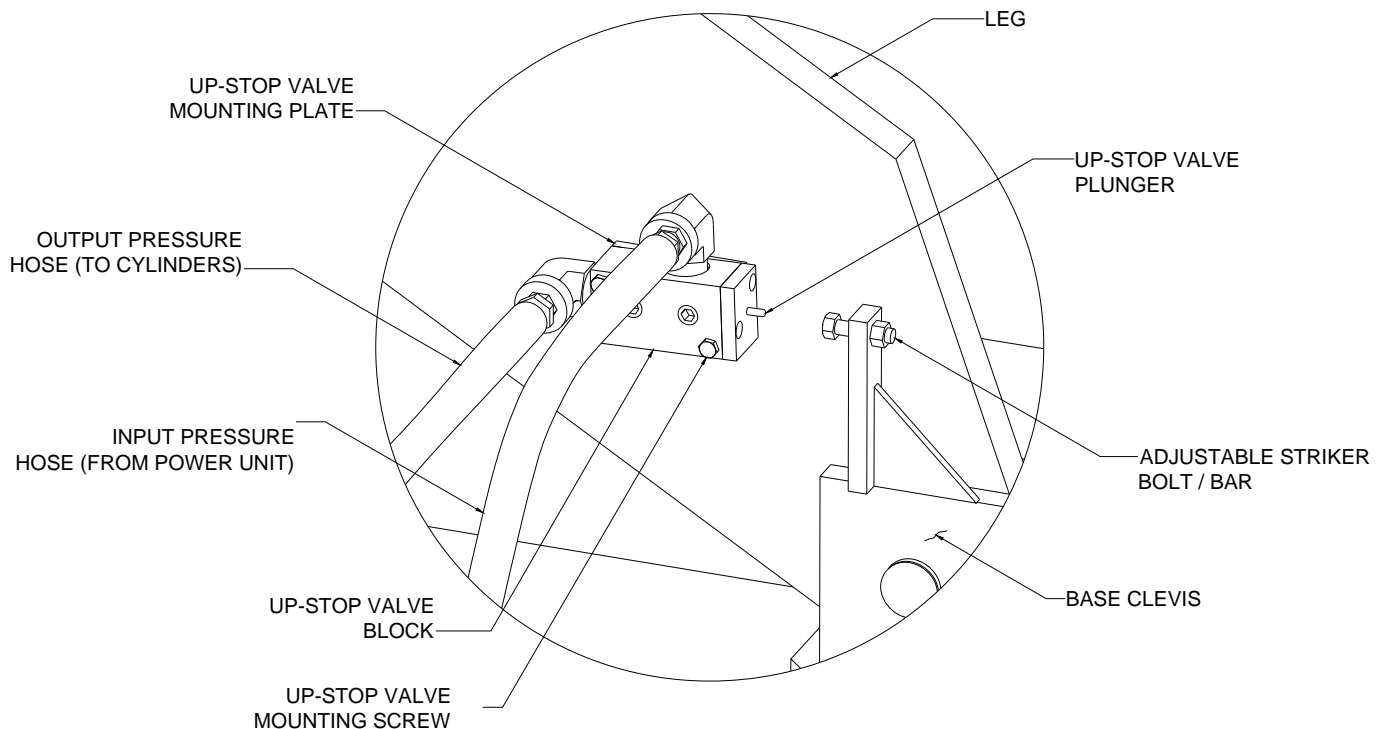
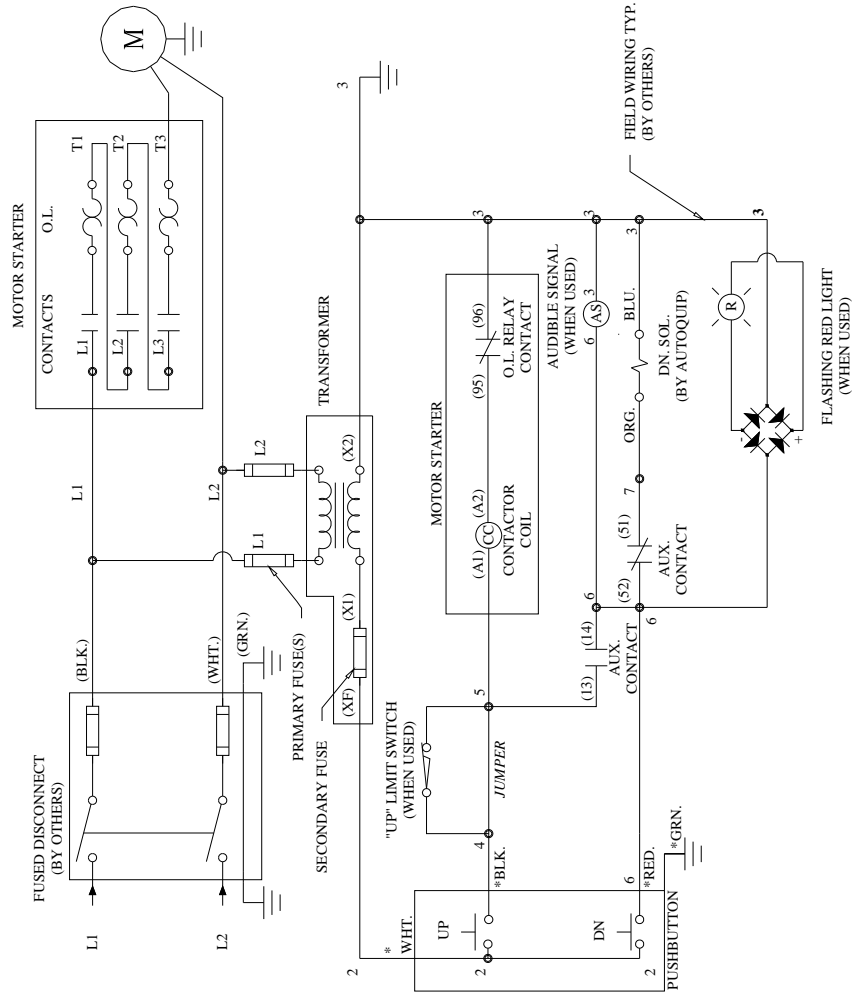

Figure 23 Up-Stop Valve System

GENERAL MAINTENANCE

65700640

- NOTES:**
- "UP" LIMIT SWITCH (OPTIONAL) WHEN USED, REMOVE JUMPER BETWEEN #4 AND #5.
 - "R" = RED FLASHING LIGHT (OPTIONAL).
 - "AS" = AUDIBLE SIGNAL (OPTIONAL).
 - SEE ASSEMBLY AND/OR SPEC SHEET FOR SPECIFIC VOLTAGES, OR CONTROLS SUPPLIED AND CONFIGURATION.
 - PUSHBUTTON SHOWN AS TYPICAL PILOT DEVICE.
 - TRANSFORMER PRIMARY CONNECTION DIAGRAMS ARE LOCATED ON INSIDE FRONT COVER OR ON DEVICE.



- * COLOR CODE OF STANDARD PENDENT PUSHBUTTON WHEN SUPPLIED.
- () INDICATES ACTUAL TERMINAL CONNECTION No. ON DEVICE

Autoquip		JOB NAME:		ORDER NO.:
REFERENCE DRAWING:	DRAWING TITLE:	ELEC SCH FOR STD & UTIL PU, SINGE PHASE		
APPROXIMATE WEIGHT:	DRAWN BY:	DATE:	QTY REQD:	PAGE:
	JMZ	02/20/01	1 OF 1	REV.
				DRAWING NUMBER:
				65700640
				SIZE:
				A

Figure 24 Generic Electric Schematic; 230V/1Ph

REPLACEMENT PARTS LIST

QTY	PART NO.	DESCRIPTION
<u>STD 5HP "VERTICAL" POWER UNIT</u>		
1	30000670	Motor
1	20000154	Motor Coupling
1	20000030	Pump Coupling
1	20000162	Coupling Insert
1	40300162	Pump
2	45901014	1/4" Dyna-Seal Washer for Deltatrol
1	64304099	Power unit, 5hp,208-230v,1ph,24CV
1	47700075	Sump Strainer
1	46100900	Hose, Pump to Deltatrol
1	64000813	Oil Reservoir
<u>OTHER ELECTRICAL</u>		
1	32701380	Down Solenoid, 24VAC
1	35150153	Control Panel, 230VAC/24VAC controls, 1ph
1	35194090	Pushbutton, UP/DN
1	65900508	Key Switch, OFF/ON
1	36203000	E-Stop
<u>HYDRAULIC</u>		
4	41800749	Velocity Fuse (plumbed to lift cylinder)
4	42800003	Lift Cylinder

REPLACEMENT PARTS LIST

<u>STANDARD OPTIONS</u>		
VARIABLES	35980140	Ultrasonic Parking Indicator
VARIABLES	36203700	Digital Keypad
1	36203790	Key Fob for Wireless Controls
1	35152790	Receiver for Wireless Controls
1	35152791	Antenna for Wireless Controls
1	36203505	Emergency Stop Pushbutton
1	35980160	Security Camera System
1	35980161	Extra Security Camera
1	35400840	Lift Motion Audible Alarm (24VDC)
1	35400760	Lift Motion Flashing Light (24VDC)
VARIABLES	34320630	Photoeye (Vehicle Present and Side Guard)
VARIABLES	34320631	Photoeye Reflector
VARIABLES	35106471	Overhead Door Interlock Kit
VARIABLES	35903630	Overhead Door Interlock Latch
VARIABLES	35106475	Single Door Interlock
VARIABLES	36203707	Motion Detector
VARIABLES	35100930	Single Door Status Switch
VARIABLES	35100920	Overhead Door Status Switch
1	64311620	7.5HP-230VAC-1PH Power Unit (6GPM) 40 AMPS
1	64311280	10HP-230VAC-1PH Power Unit (8GPM) 50 AMPS
1	64301585	5HP-230VAC-3PH Power Unit (4.5GPM)
1	30601410	5HP 1PH to 3PH Converter

REPLACEMENT PARTS LIST

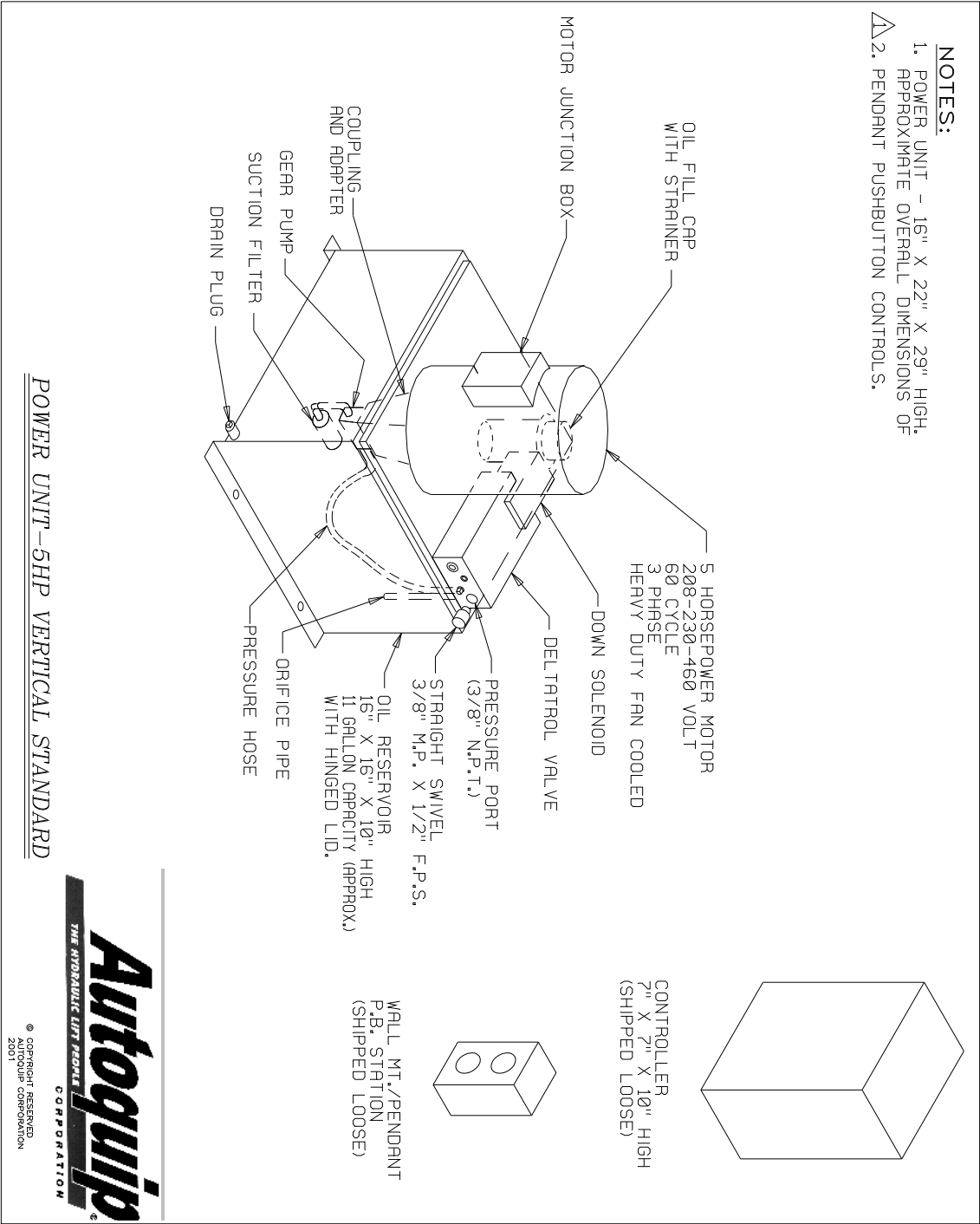

Figure 25 Vertical Power Unit Parts Detail

TROUBLESHOOTING ANALYSIS



DANGER!

To avoid personal injury, **NEVER** go under the lift platform until the load is removed and the scissors mechanism is securely blocked in the open position. See "Lift Blocking Instructions" section.

PROBLEM	POSSIBLE CAUSE AND SOLUTION
Lift raises, then lowers back slowly.	<ul style="list-style-type: none"> • The "Down" solenoid may not be seating. Remove the solenoid coil and check again. If the lift does not hold with the solenoid coil removed, the down valve cartridge should be removed with the lift in the lowered position and cleaned or replaced as necessary. • The oil line, hose, or fitting may be leaking. Check and repair if necessary. • The "check valve" in the Deltatrol valve may not be seating. This is indicated by the pump shaft and motor turning backward on their own with no power applied. Generally, this condition can be heard. Replace the pump assembly.
Lift lowers very slowly.	<ul style="list-style-type: none"> • The down-solenoid is not operating properly due to dirt or damage. • Check for pinched tubing or hose. Where pipe is used, check for obstruction in the line. • The oil is extremely viscous due to low ambient temperatures. Add or replace with lower weight oil that stays thinner in cold conditions (5W-15, etc.)

TROUBLESHOOTING ANALYSIS

PROBLEM	POSSIBLE CAUSE AND SOLUTION
Lift does not raise.	<ul style="list-style-type: none"> • 3-phase motor rotation may be reversed. Reverse only two motor electrical leads. • Check for a line or hose leak. • Check for oil shortage in the reservoir. Add oil as necessary (See Oil Requirements in the "Routine Maintenance" section.) • The load may exceed the rating. (See the "Specifications" section.) Remove the excess load. • The suction screen may be clogged, starving the pump. Remove and clean the screen. Drain and replace the oil. • The suction line may be leaking air due to a loose fitting. Tighten as needed. • The breather holes in the reservoir fill plug may be clogged. Remove and clean. • The voltage at the motor terminals may be too low to run the pump with the existing load. Check by measuring the voltage at the motor terminals, or as near as possible, <u>while the pump is running under load</u>. Reading the source voltage or pump-idling voltage is meaningless. Inadequate or incorrect wiring can starve the motor when the source voltage is ample. Correct as necessary. • The "Down" valve may be energized by faulty wiring or stuck open. Remove the solenoid with the lift in the lowered position and check. • The motor may be single phasing. Check wiring, fuses, etc. • The pump may be seized if motor is humming or blowing fuses on overload protection devices. Remove the pump. The pump should be able to be rotated by hand. Check for cracks in the housing.

TROUBLESHOOTING ANALYSIS

PROBLEM	POSSIBLE CAUSE AND SOLUTION
Lift won't lower.	<ul style="list-style-type: none"> • The solenoid coil may be incorrectly wired, burned out, not rated for the voltage, or the line voltage may be excessively low. Check voltage near the coil. • The velocity fuse may be locked. Do not attempt to remove the velocity fuse. The following steps should be followed: <ol style="list-style-type: none"> 1. Remove the load from the lift. Inspect all fittings, hoses, and other hydraulic components for leaks or damage. 2. If no leak or damage is noticed, attempt to pressurize the lifting cylinder by depressing the "UP" button on the controller for a few seconds. Immediately upon releasing the "UP" button, depress the "DOWN" button. If the lift starts to lower, continue pressing the "DOWN" button until the lift is in the fully lowered position. 3. If the lift does not lower after trying Step 2, wait approximately 10 – 15 minutes for the pressure in the hydraulic system to equalize. Then, depress the "DOWN" button until the lift is in the fully lowered position. 4. Once the lift is in the fully lowered position, bleed the air from the cylinders by depressing the "DOWN" button. Hold the "DOWN" button for approximately 60 seconds. This step may need to be repeated several times to fully remove the air in the system by raising the lift to 50% of its travel and lowering. • Should the above steps not correct the problem, contact <i>Autoquip</i> to obtain instruction for further action.

TROUBLESHOOTING ANALYSIS

PROBLEM	POSSIBLE CAUSE AND SOLUTION
Lift seems bouncy during operation.	<ul style="list-style-type: none"> Lower the lift to collapsed position and continue to hold "DOWN" button an additional 10-30 seconds to bleed air from the cylinder bleed screws. Do not confuse spongy or jerky operation with small surges that may occur when operating on rough or uneven floors <div style="text-align: center; margin: 10px 0;">  </div> <p style="text-align: center; margin: 0;">WARNING!</p> <p style="text-align: center; margin: 0;">Do not remove the bleed screw! This could cause the lift to drop rapidly, resulting in damage to the lift or cause personal injury. Loosen the screw carefully to let air out of the system.</p> <ul style="list-style-type: none"> Check for oil starvation.
Motor labors or heats excessively.	<ul style="list-style-type: none"> The voltage may be low. Check at the motor terminals while the pump is <u>running loaded</u>, not at the line source or while the pump is idling. Inadequate wiring can starve the motor even when the source voltage is ample. Running against relief pressure unnecessarily due to over loaded lift or hitting physical stops. Failure to observe wiring diagram on nameplate for proper voltage connections. The pump may be binding from oil starvation, which develops high internal heat. Check for low oil level or closed breather holes in the reservoir fill plug. The pump can be irreparably damaged by oil starvation and may have to be replaced.

GLOSSARY OF TERMS

TERM	DEFINITION
Anchors	Bolts used to fix guides to the floor and walls
ATF	Automatic transmission fluid
Capacity	Maximum allowable load
Canopy	The upper platform assembly that fills the garage floor opening when lowered
Carriage	The lower platform assembly that travels in the guides and holds the canopy
Controls	Any electrical device used in the operation of a lift, which normally includes operator push button stations, control boxes, limit switches, interlocks, etc.
Cylinder	A device which converts hydraulic pressure to linear movement.
Cycle	The lift is considered to have operated one cycle any time the motor starts.
Down solenoid	An electrical mechanical device that, when electrically energized, opens the down valve to allow hydraulic fluid to return to the reservoir under force of gravity.
Enclosure	A structure surrounding the lift to prevent anything from interfering with normal operation of the lift, and to protect personnel.
Gate / Door	A device that opens and closes to allow access to the carriage for loading and unloading. Normally single or bi-part swing style, sometimes fire-rated.
Hydraulic	Operation by movement and force of liquid
Interlock	An electrical mechanical system for doors or gates to prevent operation of the lift if all the gates are not closed or if the lift platform is not at the desired level.
Limit Switch	An electrical device by which the location of the lift may be sensed or detected within predetermined limits.
Load height	The maximum height of the vehicle which a carriage can accommodate.
Motor starter	An electrical controller for accelerating a motor from rest to normal speed.
Platform	The horizontal surface of the deck where the vehicle is parked.
Power unit	An assembly including, but not limited to the motor, pump, reservoir, and the Deltatrol valve.
Pressure relief valve	A valve that can be set to a predetermined pressure. If the pressure is exceeded, the valve will open to prevent damage to the hydraulic system.
Snap chain	A length of chain with a clasp on the end to close off the operating end of a carriage.
Travel	The vertical distance "travelled" by the carriage when measured from its fully lowered to its fully raised position at the garage floor level.